

# EL SERIES

## MACHINE VISION LIGHTING EL PRODUCT CATALOG

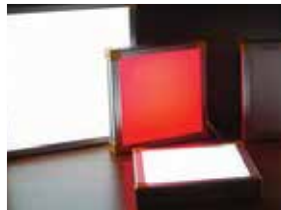

**WORLDWIDE NETWORK**

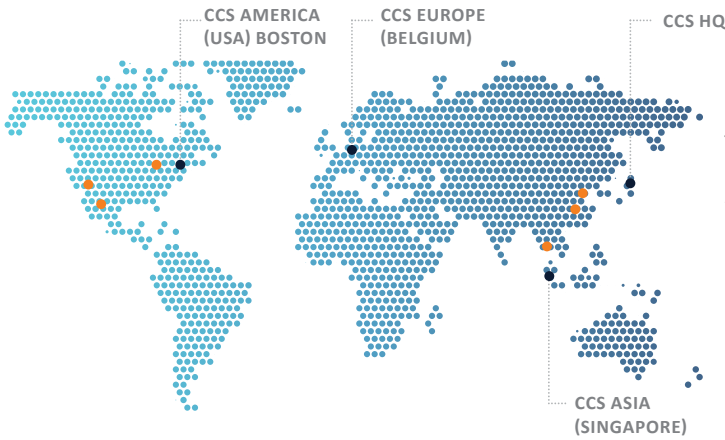

CCS has a world-wide network to support you throughout the world.

We are dedicated to provide you with the optimal lighting solution for image processing applications to improve product quality and production yield.

**INTRODUCTION**

With the EL Series, CCS brings to the market a new range of high-quality plug & play lighting that achieves an innovative advancement in flexible design. The new EL Series includes bar lights and ring lights, which have built-in controllers that deliver auto-strobe functionality. The auto-strobe functionality allows for easy and safe overdriving, as well as a continuous mode. The EL Series also includes back lights and flat lights with a camera hole, both with integrated dimming controllers, for inspections with a large field of view

Utilizing innovative technology, the EL Series delivers a unique flexibility and convenience to Machine Vision lighting. Lenses can be adjusted by hand to control the emission angle of the light beam. In addition to the size of the light and different wavelengths, users can choose from three different diffusers and other optical accessories to easily design their optimal lighting solution.

The EL Series expands the current line-up with IP options (IP67 and IP69K) for inspection applications affected by high-exposure to dust or water, such as the food-processing and pharmaceutical industries. The EL Series also includes structured LED lighting designed for 3D reconstruction, stereovision, and alignment applications using interchangeable masks to project the desired pattern clearly at a powerful output.

**DIRECT ILLUMINATION**

Flood Type Bar Light ..... 4  
High Power Smart Brick Light ..... 12  
Flexible Power Ring Light..... 22

**DIFFUSED ILLUMINATION**

Homogeneous Back Light ..... 26  
Homogeneous Flat Light with camera hole ..... 29  
Linescan Homogeneous Flat Light ..... 32

**STRUCTURED LIGHT**

3D Projector ..... 38

**ACCESSORIES**

Cables ..... 45  
Camera fixing & lightings fasteners ..... 46

**INFORMATION**

Warranty Information..... 47

## FLOOD TYPE BAR LIGHT

### ELB SERIES

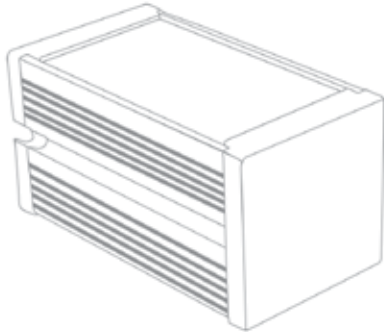

The ELB Series is a **high-power** flood type bar light designed around flexibility to answer the needs of many machine vision applications.

With the ELB Series, it is easy to adjust the product mechanically, optically, and electronically. This makes it easy for the ELB Series to adapt to any application requirement. For instance, users can select the correct lens position depending on the irradiation distance. The ELB Series is also shipped with three different diffuser plates, so that the uniformity can be adjusted to the needs of the user.

When compared to continuous mode, the **integrated controller with auto-strobe** functionality allows for a 300% increase in intensity while being strobed.

### MAIN FEATURES

- Standard delivered as a package
- Very intense and uniform illuminated area
- Long lifetime and minimal maintenance
- Standard connections and fasteners

Flexible: Adjustable illumination angles (4 angles) & different diffusers



Connector	M12 - 4 contacts or M12P - 4 contacts (depending on the length)
Power supply	24VDC
Illumination mode	Strobe or continuous mode
Electronical mode	Auto-strobe
Available wavelength	White, UV, Blue, Green, Red, IR
Available sizes	From 100mm to 1600mm
Width x height	51mm x 49mm
Fastener	One rail for M4 T-nut on the back and one rail for M6 T-nut on the side
Material	Device body: Aluminum alloy & ABS; Window: PMMA
Working temperature	0° to 50° C
IP code	IP50

### APPLICATIONS

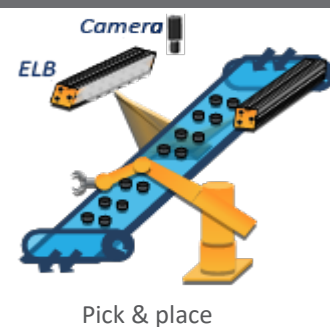
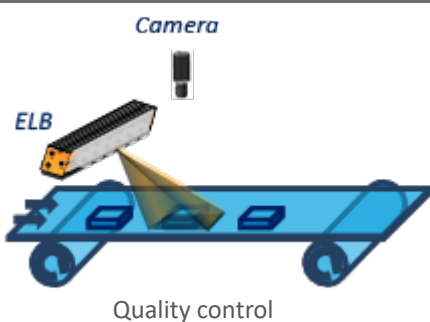

## OPTICAL FLEXIBILITY

### How to change the configuration of the ELB



### Diffuser

The ELB Series is shipped with three different diffusers. Depending on the uniformity needed for the application, the user can select and easily change to the diffuser that fulfills the application requirements.

Clear (CW)

Semi-diffused (SD)

Diffused (DF)



### Lens Position

The lens position of the ELB Series is flexible and can easily be adjusted depending on the irradiation distance.



### Optical options

With the polarizer for the ELB Series, it is possible to eliminate glare from your workpiece, making it easier to acquire a suitable image for your application.



The ELB Series also offers a linescan accessory, transforming the ELB Series into a line light useable as either a brightfield or darkfield illumination.

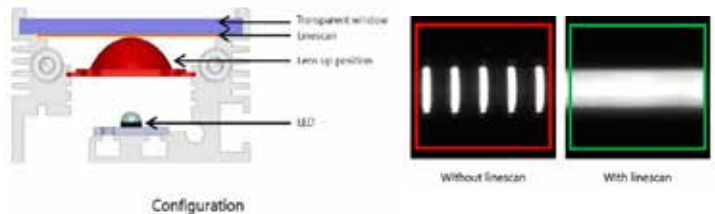

When the lens is positioned in P3, the polarizer and the linescan accessory cannot be used together. If necessary, a thinner polarizer is available.

### The L2 version: ELB-L2

The ELB Series is also available with 1 led on every 2 positions, which is called the ELB-L2 Series. For further information, please contact your CCS representative.

**DIMENSIONS (MM)**

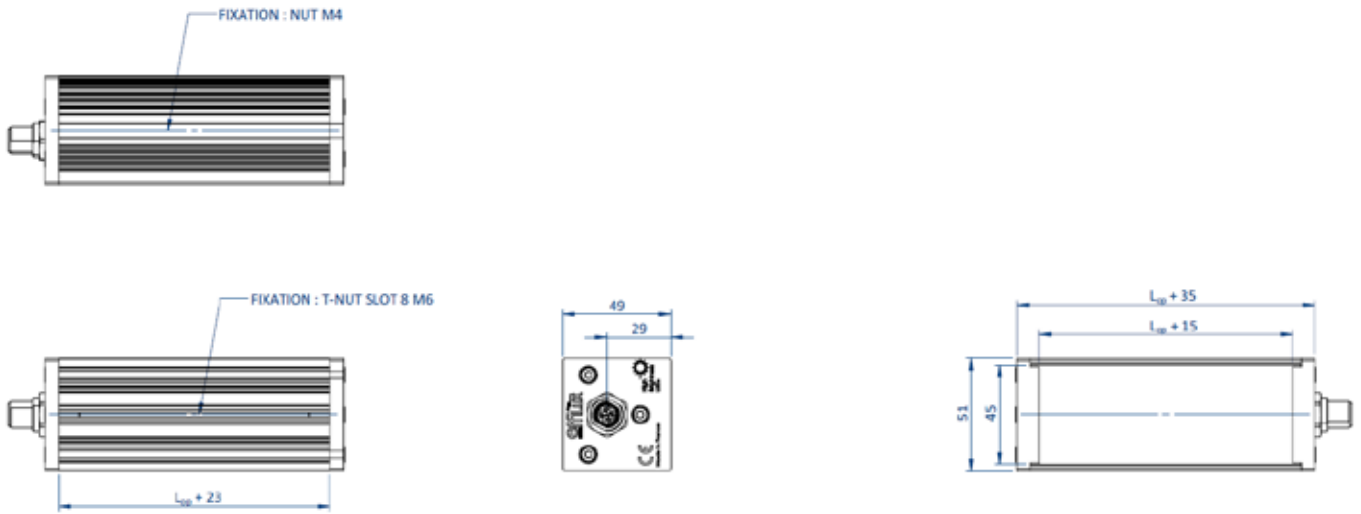

**ELECTRONICAL SPECIFICATIONS**



Contact arrangement

When using the ELB Series, please use a 24VDC power supply.  
Please note that the trigger pin needs to be connected when using the ELB Series.

Contact arrangement	Number	Color Contact	Designation
<p>M12 male connector    M12 Power male connector</p> <p><i>TYPE OF CONNECTOR DEPENDS ON THE LENGTH OF THE ELB</i></p>	1	Brown	+24V DC
	2	White	n.a.
	3	Blue	GND
	4	Black	<b>PNP TRIGGER [trigger for rising edge] for auto-strobe</b> Light ON if $V_{PNP} > 3VDC$ max 24VDC - Analog Voltage

Auto-strobe feature

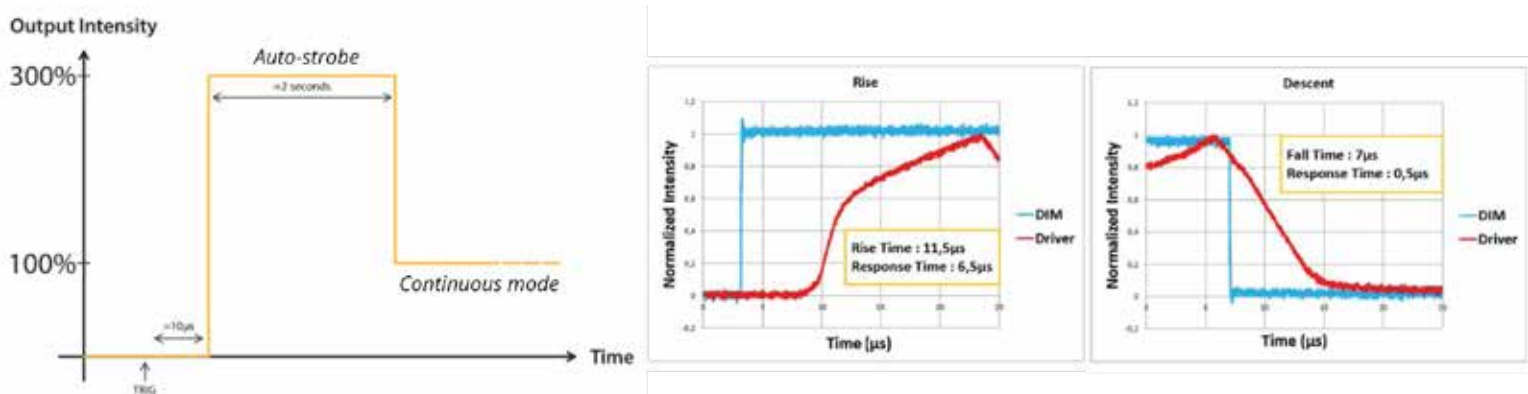

PRODUCT LINE UP - PACKAGES

The ELB Series is standard delivered as a **package**: the product in the classic configuration (SD diffuser and the lens at P2 position) and the two other diffusers (DF and CW). This allows the users to select the correct diffuser for their application needs.



ELB : Standard version

The power consumption is given for white products, and may differ for other wavelengths. The power consumption will be specified on the products.

PRODUCT LINE UP

Series	Part Number	Color	Wavelength / Color temperature	Power Consumption		Connector	Weight	Optical Length (L <sub>op</sub> )
				Strobe	Continuous			
ELB	ELB-100SW	White	5500 K ± 500 K	20W	8W	M12	400g	100mm
ELB	ELB-100UV	Ultraviolet	405nm					
ELB	ELB-100BL	Blue	465nm					
ELB	ELB-100GR	Green	525nm					
ELB	ELB-100RD	Red	625nm					
ELB	ELB-100IR	Infrared	850nm	40W	15W	M12	700g	200mm
ELB	ELB-200SW	White	5500 K ± 500 K					
ELB	ELB-200UV	Ultraviolet	405nm					
ELB	ELB-200BL	Blue	465nm					
ELB	ELB-200GR	Green	525nm					
ELB	ELB-200RD	Red	625nm	60W	20W	M12	1000g	300mm
ELB	ELB-200IR	Infrared	850nm					
ELB	ELB-300SW	White	5500 K ± 500 K					
ELB	ELB-300UV	Ultraviolet	405nm					
ELB	ELB-300BL	Blue	465nm					
ELB	ELB-300GR	Green	525nm	80W	30W	M12	1300g	400mm
ELB	ELB-300RD	Red	625nm					
ELB	ELB-300IR	Infrared	850nm					
ELB	ELB-400SW	White	5500 K ± 500 K					
ELB	ELB-400UV	Ultraviolet	405nm					
ELB	ELB-400BL	Blue	465nm	95W	35W	M12	1600g	500mm
ELB	ELB-400GR	Green	525nm					
ELB	ELB-400RD	Red	625nm					
ELB	ELB-400IR	Infrared	850nm					
ELB	ELB-500SW	White	5500 K ± 500 K					
ELB	ELB-500UV	Ultraviolet	405nm	115W	45W	M12	1900g	600mm
ELB	ELB-500BL	Blue	465nm					
ELB	ELB-500GR	Green	525nm					
ELB	ELB-500RD	Red	625nm					
ELB	ELB-500IR	Infrared	850nm					
ELB	ELB-600SW	White	5500 K ± 500 K	135W	50W	M12	2200g	700mm
ELB	ELB-600UV	Ultraviolet	405nm					
ELB	ELB-600BL	Blue	465nm					
ELB	ELB-600GR	Green	525nm					
ELB	ELB-600RD	Red	625nm					
ELB	ELB-600IR	Infrared	850nm	135W	50W	M12	2200g	700mm
ELB	ELB-700SW	White	5500 K ± 500 K					
ELB	ELB-700UV	Ultraviolet	405nm					
ELB	ELB-700BL	Blue	465nm					
ELB	ELB-700GR	Green	525nm					
ELB	ELB-700RD	Red	625nm					
ELB	ELB-700IR	Infrared	850nm					

Series	Part Number	Color	Wavelength / Color temperature	Power Consumption		Connector	Weight	Optical Length (L <sub>op</sub> )
				Strobe	Continuous			
ELB	ELB-800SW	White	5500 K ± 500 K	155W	55W	M12	2500g	800mm
ELB	ELB-800UV	Ultraviolet	405nm					
ELB	ELB-800BL	Blue	465nm					
ELB	ELB-800GR	Green	525nm					
ELB	ELB-800RD	Red	625nm					
ELB	ELB-800IR	Infrared	850nm					
ELB	ELB-900SW	White	5500 K ± 500 K	175W	60W	M12P	2800g	900mm
ELB	ELB-900UV	Ultraviolet	405nm					
ELB	ELB-900BL	Blue	465nm					
ELB	ELB-900GR	Green	525nm					
ELB	ELB-900RD	Red	625nm					
ELB	ELB-900IR	Infrared	850nm					
ELB	ELB-1000SW	White	5500 K ± 500 K	190W	65W	M12P	3100g	1000mm
ELB	ELB-1000UV	Ultraviolet	405nm					
ELB	ELB-1000BL	Blue	465nm					
ELB	ELB-1000GR	Green	525nm					
ELB	ELB-1000RD	Red	625nm					
ELB	ELB-1000IR	Infrared	850nm					
ELB	ELB-1100SW	White	5500 K ± 500 K	210W	70W	M12P	3400g	1100mm
ELB	ELB-1100UV	Ultraviolet	405nm					
ELB	ELB-1100BL	Blue	465nm					
ELB	ELB-1100GR	Green	525nm					
ELB	ELB-1100RD	Red	625nm					
ELB	ELB-1100IR	Infrared	850nm					
ELB	ELB-1200SW	White	5500 K ± 500 K	230W	75W	M12P	3700g	1200mm
ELB	ELB-1200UV	Ultraviolet	405nm					
ELB	ELB-1200BL	Blue	465nm					
ELB	ELB-1200GR	Green	525nm					
ELB	ELB-1200RD	Red	625nm					
ELB	ELB-1200IR	Infrared	850nm					
ELB	ELB-1300SW	White	5500 K ± 500 K	250W	85W	M12P	4000g	1300mm
ELB	ELB-1300UV	Ultraviolet	405nm					
ELB	ELB-1300BL	Blue	465nm					
ELB	ELB-1300GR	Green	525nm					
ELB	ELB-1300RD	Red	625nm					
ELB	ELB-1300IR	Infrared	850nm					
ELB	ELB-1400SW	White	5500 K ± 500 K	270W	90W	M12P	4300g	1400mm
ELB	ELB-1400UV	Ultraviolet	405nm					
ELB	ELB-1400BL	Blue	465nm					
ELB	ELB-1400GR	Green	525nm					
ELB	ELB-1400RD	Red	625nm					
ELB	ELB-1400IR	Infrared	850nm					
ELB	ELB-1500SW	White	5500 K ± 500 K	290W	95W	M12P	4600g	1500mm
ELB	ELB-1500UV	Ultraviolet	405nm					
ELB	ELB-1500BL	Blue	465nm					
ELB	ELB-1500GR	Green	525nm					
ELB	ELB-1500RD	Red	625nm					
ELB	ELB-1500IR	Infrared	850nm					
ELB	ELB-1600SW	White	5500 K ± 500 K	310W	100W	M12P	4900g	1600mm
ELB	ELB-1600UV	Ultraviolet	405nm					
ELB	ELB-1600BL	Blue	465nm					
ELB	ELB-1600GR	Green	525nm					
ELB	ELB-1600RD	Red	625nm					
ELB	ELB-1600IR	Infrared	850nm					

### ELB-L2 : 1 LED on 2 positions version

The power consumption is given for white products, and may differ for other wavelengths. The power consumption will be specified on the products.

Series	Part Number	Color	Wavelength / Color temperature	Power Consumption		Connector	Weight	Optical Length (L <sub>op</sub> )
				Strobe	Continuous			
ELB-L2	ELB-L2-200SW	White	5500 K ± 500 K	20W	8W	M12	700g	200mm
ELB-L2	ELB-L2-200UV	Ultraviolet	405nm					
ELB-L2	ELB-L2-200BL	Blue	465nm					
ELB-L2	ELB-L2-200GR	Green	525nm					
ELB-L2	ELB-L2-200RD	Red	625nm					
ELB-L2	ELB-L2-200IR	Infrared	850nm					



Series	Part Number	Color	Wavelength / Color temperature	Power Consumption		Connector	Weight	Optical Length (L <sub>op</sub> )
				Strobe	Continuous			
ELB-L2	ELB-L2-400SW	White	5500 K ± 500 K	40W	15W	M12	1300g	400mm
ELB-L2	ELB-L2-400UV	Ultraviolet	405nm					
ELB-L2	ELB-L2-400BL	Blue	465nm					
ELB-L2	ELB-L2-400GR	Green	525nm					
ELB-L2	ELB-L2-400RD	Red	625nm					
ELB-L2	ELB-L2-400IR	Infrared	850nm	60W	20W	M12	1900g	600mm
ELB-L2	ELB-L2-600SW	White	5500 K ± 500 K					
ELB-L2	ELB-L2-600UV	Ultraviolet	405nm					
ELB-L2	ELB-L2-600BL	Blue	465nm					
ELB-L2	ELB-L2-600GR	Green	525nm					
ELB-L2	ELB-L2-600RD	Red	625nm	80W	30W	M12	2500g	800mm
ELB-L2	ELB-L2-800SW	White	5500 K ± 500 K					
ELB-L2	ELB-L2-800UV	Ultraviolet	405nm					
ELB-L2	ELB-L2-800BL	Blue	465nm					
ELB-L2	ELB-L2-800GR	Green	525nm					
ELB-L2	ELB-L2-800RD	Red	625nm	95W	35W	M12	3100g	1000mm
ELB-L2	ELB-L2-800IR	Infrared	850nm					
ELB-L2	ELB-L2-1000SW	White	5500 K ± 500 K					
ELB-L2	ELB-L2-1000UV	Ultraviolet	405nm					
ELB-L2	ELB-L2-1000BL	Blue	465nm					
ELB-L2	ELB-L2-1000GR	Green	525nm	115W	45W	M12	3700g	1200mm
ELB-L2	ELB-L2-1000RD	Red	625nm					
ELB-L2	ELB-L2-1000IR	Infrared	850nm					
ELB-L2	ELB-L2-1200SW	White	5500 K ± 500 K					
ELB-L2	ELB-L2-1200UV	Ultraviolet	405nm					
ELB-L2	ELB-L2-1200BL	Blue	465nm	135W	50W	M12	4300g	1400mm
ELB-L2	ELB-L2-1200GR	Green	525nm					
ELB-L2	ELB-L2-1200RD	Red	625nm					
ELB-L2	ELB-L2-1200IR	Infrared	850nm					
ELB-L2	ELB-L2-1400SW	White	5500 K ± 500 K					
ELB-L2	ELB-L2-1400UV	Ultraviolet	405nm	155W	55W	M12	4900g	1600mm
ELB-L2	ELB-L2-1400BL	Blue	465nm					
ELB-L2	ELB-L2-1400GR	Green	525nm					
ELB-L2	ELB-L2-1400RD	Red	625nm					
ELB-L2	ELB-L2-1400IR	Infrared	850nm					
ELB-L2	ELB-L2-1600SW	White	5500 K ± 500 K	155W	55W	M12	4900g	1600mm
ELB-L2	ELB-L2-1600UV	Ultraviolet	405nm					
ELB-L2	ELB-L2-1600BL	Blue	465nm					
ELB-L2	ELB-L2-1600GR	Green	525nm					
ELB-L2	ELB-L2-1600RD	Red	625nm					
ELB-L2	ELB-L2-1600IR	Infrared	850nm					

OPTICAL ACCESSORIES

Polarizer	
Part Number	Applicable LED Unit
PL-ELB-100	ELB-100 / ELFB-100
PL-ELB-200	ELB-200 / ELB-L2-200 / ELFB-200
PL-ELB-300	ELB-300 / ELFB-300
PL-ELB-400	ELB-400 / ELB-L2-400 / ELFB-400
PL-ELB-500	ELB-500 / ELFB-500
PL-ELB-600	ELB-600 / ELB-L2-600 / ELFB-600
PL-ELB-700	ELB-700 / ELFB-700
PL-ELB-800	ELB-800 / ELB-L2-800 / ELFB-800
PL-ELB-900	ELB-900 / ELFB-900
PL-ELB-1000	ELB-1000 / ELB-L2-1000 / ELFB-1000
PL-ELB-1100	ELB-1100 / ELFB-1100
PL-ELB-1200	ELB-1200 / ELB-L2-1200 / ELFB-1200
PL-ELB-1300	ELB-1300 / ELFB-1300
PL-ELB-1400	ELB-1400 / ELB-L2-1400 / ELFB-1400
PL-ELB-1500	ELB-1500 / ELFB-1500
PL-ELB-1600	ELB-1600 / ELB-L2-1600 / ELFB-1600

Linescan (linear lighting or darkfield lighting)	
Part Number	Applicable LED Unit
LS-ELB-100	ELB-100
LS-ELB-200	ELB-200 / ELB-L2-200
LS-ELB-300	ELB-300
LS-ELB-400	ELB-400 / ELB-L2-400
LS-ELB-500	ELB-500
LS-ELB-600	ELB-600 / ELB-L2-600
LS-ELB-700	ELB-700
LS-ELB-800	ELB-800 / ELB-L2-800
LS-ELB-900	ELB-900
LS-ELB-1000	ELB-1000 / ELB-L2-1000
LS-ELB-1100	ELB-1100
LS-ELB-1200	ELB-1200 / ELB-L2-1200
LS-ELB-1300	ELB-1300
LS-ELB-1400	ELB-1400 / ELB-L2-1400
LS-ELB-1500	ELB-1500
LS-ELB-1600	ELB-1600 / ELB-L2-1600

The linescan accessory will be integrated in longer lights. For further information, please contact your CCS representative.

For cables, please refer to the datasheet of the ECB cables series.

For fasteners and camera supports, please refer to the datasheet of the BK fasteners series.

## CUSTOM - ON REQUEST

### Options available on request

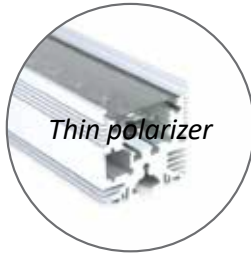
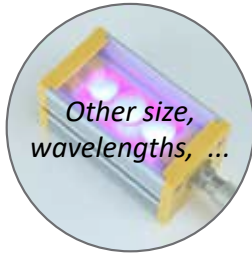

### Example of custom



## EU DIRECTIVE



In accordance with EU machinery directive, EMC directive, and low voltage directive, machines and electronic devices not marked with the CE logo are subject to distribution restrictions within the EU. All EL Series LED illumination products excluding power supply conform to corresponding EN regulations. These products will maintain the EU mandate compatibility of our customers' machinery and electronic devices.

## ROHS DIRECTIVE

All products from the EL Series comply with the RoHS Directive.



## HIGH POWER SMART BRICK LIGHT

### ELSB SERIES



The ELSB Series has a double row of **high-powered** LEDs for more intensity. This answers the need for a higher intensity that comes with the increase in line speeds of machine vision applications.

Like the ELB Series, the ELSB is highly **flexible** and allows for easy adjustment of the lens position and diffuser plates. The ELSB Series has an **IP67 rating** to cope with harsher working environments, where dust and water are constant factors.

The **integrated controller** of the ELSB Series offers flexibility to the user. With this integrated controller, the user can **dim** the ELSB Series to the required illumination level. The user can also make use of the **auto-strobe** functionality, increasing the intensity with 700%.

### MAIN FEATURES

- Very intense and uniform illuminated area
- Long lifetime and minimal maintenance
- Waterproof
- Chainable : Double I/O connectors
- Flexible: Adjustable illumination angles (4 angles) & different windows



Connector	2 x M12 - 5 contacts (1 male & 1 female)
Power supply	24VDC
Illumination mode	Strobe or continuous mode
Electrical mode	Auto-strobe
Available wavelength	White, UV, Blue, Green, Red, IR
Available sizes	3 available sizes: 55mm, 105mm & 285mm
Width x Height	32mm x 87mm
Fastener	4 x M4 screw + 4 x M3 screw + 2 x M4 holes
Material	Device body: Aluminum alloy & ABS; Window: PMMA
Working temperature	0° to 50° C
IP code	IP67

### APPLICATIONS

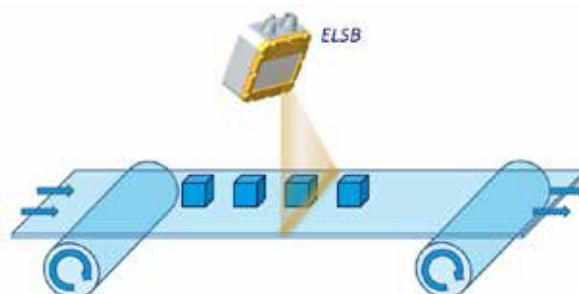

## OPTICAL FLEXIBILITY

### Diffuser

The ELSB Series is shipped with three different diffusers. Depending on the uniformity needed for the application, the user can select and easily change to the diffuser that fulfills the application requirements.



### Lens Position

The lens position of the ELSB Series is flexible and can easily be adjusted depending on the irradiation distance.

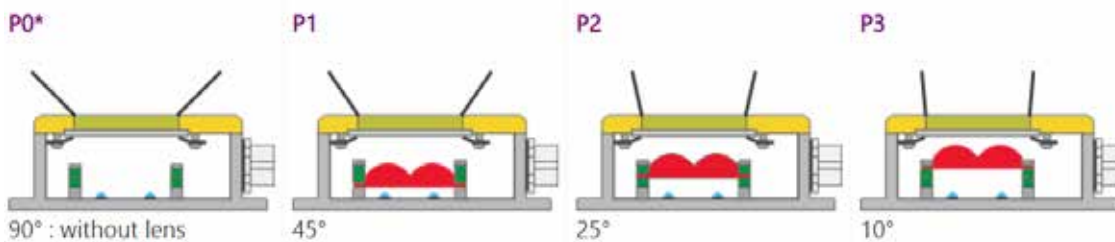

### How to change the configuration of the ELSB

The position of the lens array can be configured by adjusting the two spacers inside the ELSB Series. Please note that opening the product might compromise the IP-rating, if not closed properly afterwards.

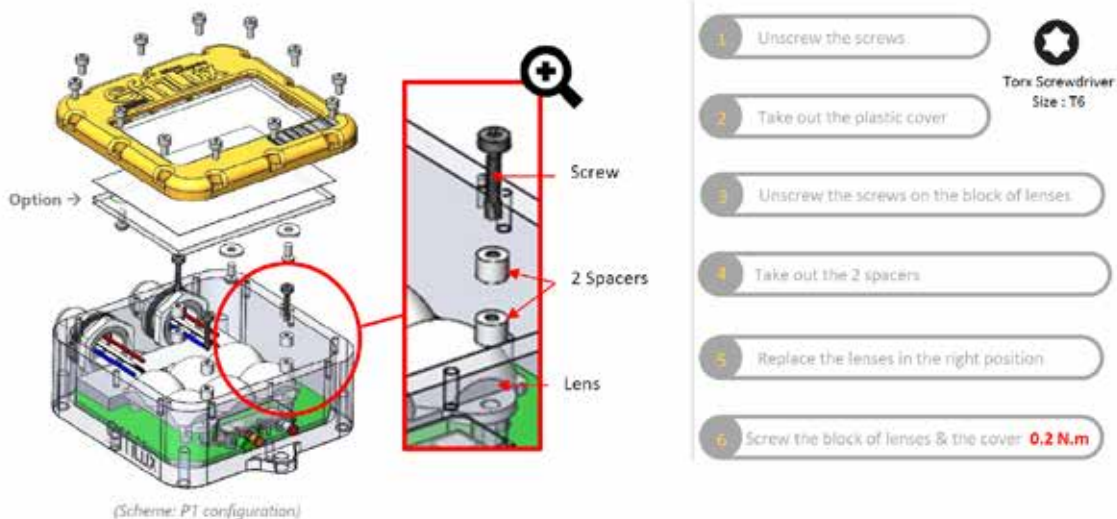

### Optical option

With the polarizer for the ELB Series, it is possible to eliminate glare from your workpiece, making it easier to acquire a suitable image for your application.



**DIMENSIONS (MM)**

ELSB-55

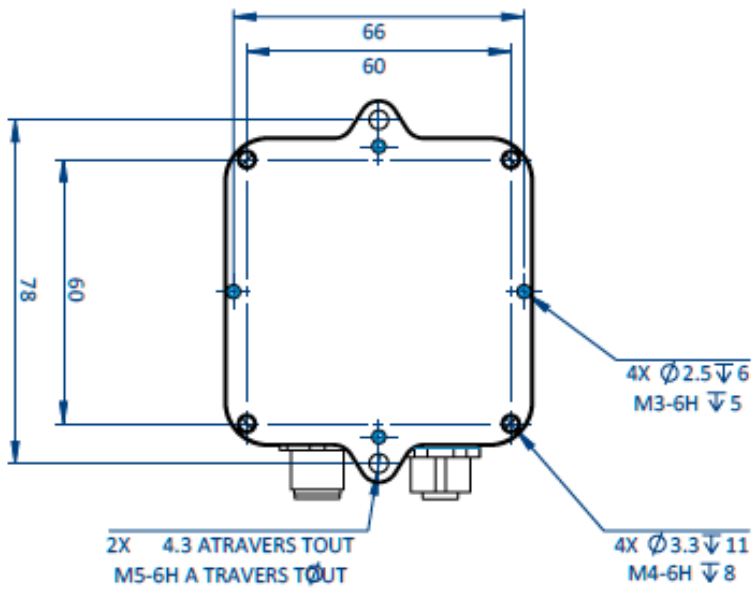
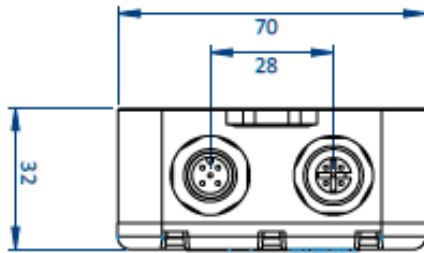
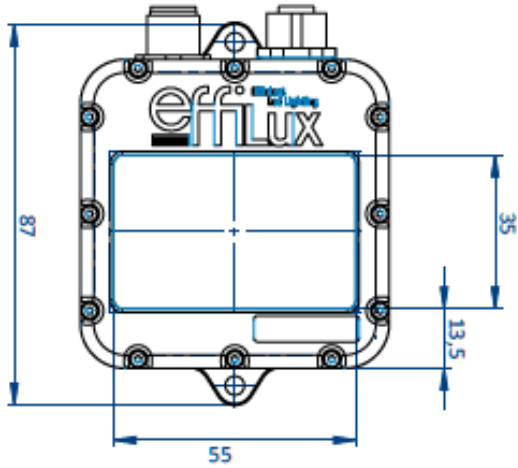

DIMENSIONS (MM)

ELSB-105

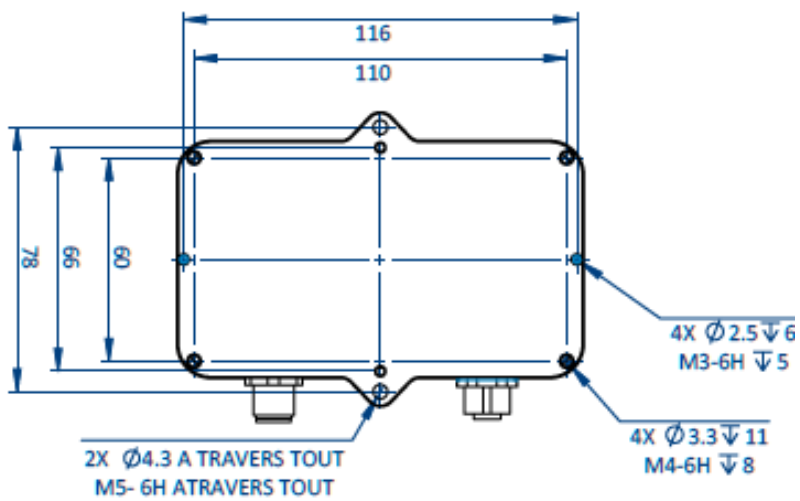
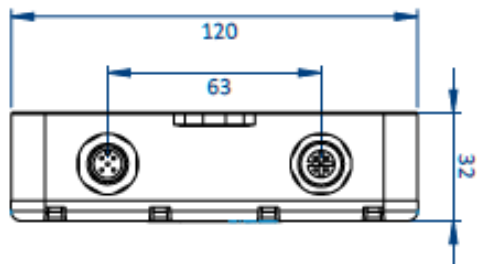
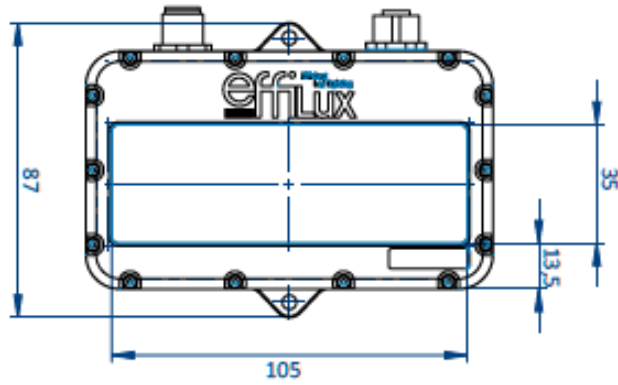

**DIMENSIONS (MM)**

ELSB-285

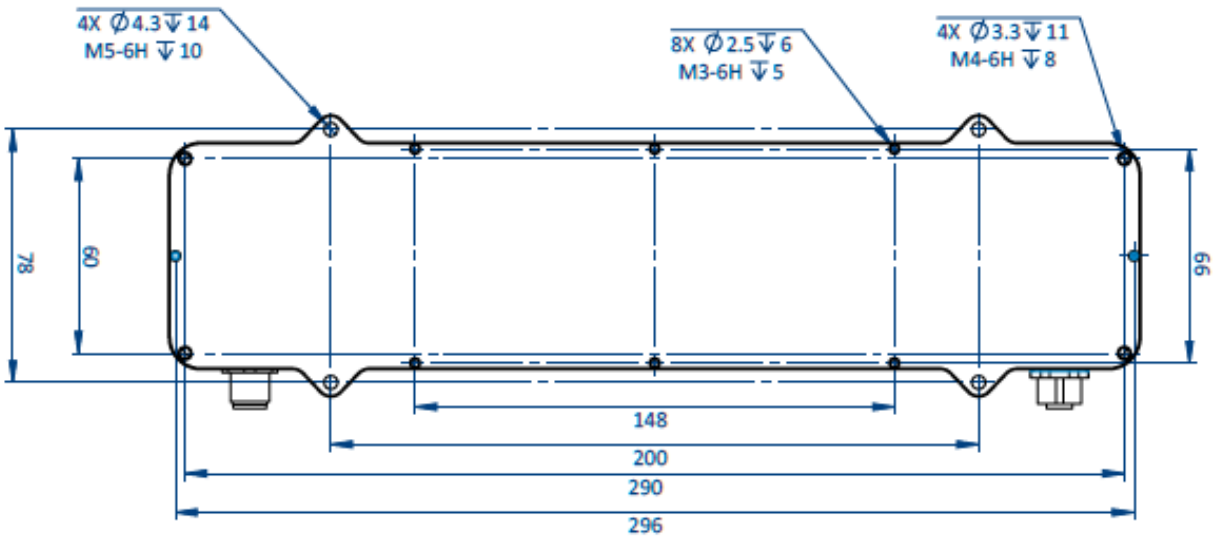
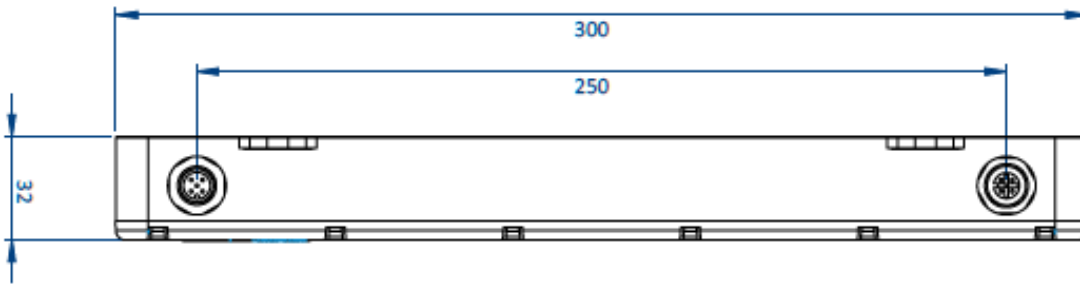
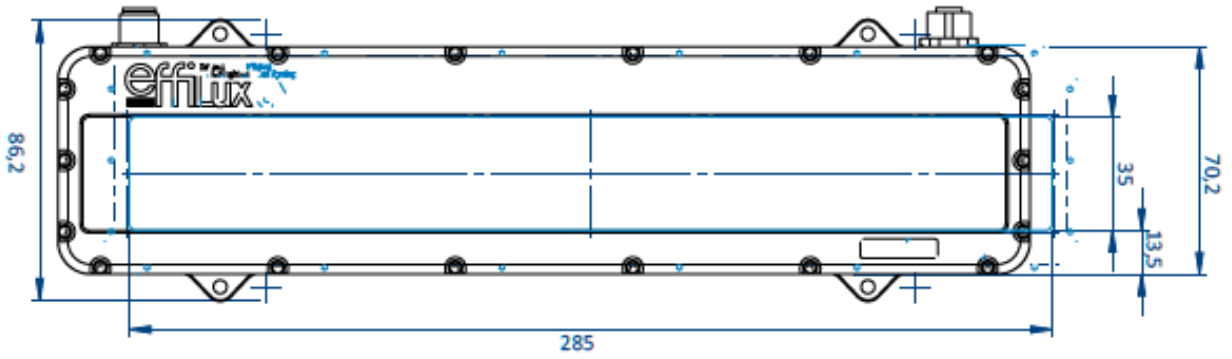





ELECTRONICAL SPECIFICATIONS

Contact arrangement

When using the ELSB Series, please use a 24VDC power supply.

Please note that the trigger pin needs to be connected when using the ELSB Series.

Contact arrangement	Number	Color Contact	Designation
<p>MALE FEMALE</p> <p>M12 male &amp; female connectors</p>	1	Brown	+24V
	2	White	NPN TRIGGER (trigger on falling edge] for auto-strobe Light ON if $V_{NPN} < 1.5V$ DC max consumption = 0.1 mA - <b>max 24V - Analog Voltage</b>
	3	Blue	GND
	4	Black	PNP TRIGGER [trigger for rising edge] for auto-strobe Light ON if $V_{PNP} > 3V$ DC max consumption = 2mA - <b>max 24V - Analog Voltage</b>
	5	Grey	AIC: Analog Intensity Control for Dimming Control Consumption = 1mA @ 10V & 2mA @24V <b>Suggested dimming range: min 5V - max 24V</b>

Electronical Modes

ELECTRONICAL MODES						
Mode	Designation	Contact arrangement				
		pin1	pin2	pin3	pin4	pin5
<p><b>AUTO-STROBE</b></p>	<p>PNP: Strobe control triggered on rising edge.</p> <p>N.B: For the strobe mode please respect a duty cycle (DC) lower than 0.25.</p>	+24V	not connected (≠ 0V)	GND	> 3VDC max 24VDC	not connected (≠ 0V)
	<p>NPN: Strobe control triggered on falling edge.</p> <p>N.B: For the strobe mode please respect a duty cycle (DC) lower than 0.25.</p>	+24V	< 1.5Vdc	GND	not connected (≠ 0V)	not connected (≠ 0V)
<p><b>DIMMING CONTROL</b></p>	<p>Analog intensity control</p> <p>LED OFF: 0-3V LED ON: 3V (40%) - 10V (100%) LED ON: 10-24V (100%)</p>	+24V	not connected (≠ 0V)	GND	not connected (≠ 0V)	AIC: 0-24V See scheme
<p><b>TEST MODE</b></p>	<p>LEDs are supplied with <math>I_{max}</math> (700%) until default temperature is activated. Do not use this mode with any external triggers.</p> <p>Signal consumption : 4mA <b>Do not touch the product (HOT)</b></p>	+24V	> 3VDC max 24VDC (or not connected)	GND	> 3VDC max 24VDC	> 3VDC max 24VDC

**LED INDICATOR**



**Green LED ON:** Power Supply Connected

**Red LED ON:** Default Temperature at 65°C

**⚠ Do not touch the product! Please wait 5 minutes before handling the product again.**



**Orange LED ON:** Mode

Mode	Frequency
PNP & NPN	Flash at the light frequency
AIC	Flash at 1 Hz
TEST	Flash at 6 Hz

**PRODUCT LINE UP**

The power consumption is given for white products, and may differ for other wavelengths. The power consumption will be specified on the products.

**ELSB-55**

Series	Part Number	Color	Wavelength / Color temperature	Max Power Consumption	Connectors	Weight
ELSB	ELSB-55SW	White	5500 K ± 500 K	15W	2 x M12-5 (M&F)	180g
ELSB	ELSB-55UV	Ultraviolet	405nm			
ELSB	ELSB-55BL	Blue	465nm			
ELSB	ELSB-55GR	Green	525nm			
ELSB	ELSB-55RD	Red	625nm			
ELSB	ELSB-55IR	Infrared	850nm			

**ELSB-105**

Series	Part Number	Color	Wavelength / Color temperature	Max Power Consumption	Connectors	Weight
ELSB	ELSB-105SW	White	5500 K ± 500 K	30W	2 x M12-5 (M&F)	300g
ELSB	ELSB-105UV	Ultraviolet	405nm			
ELSB	ELSB-105BL	Blue	465nm			
ELSB	ELSB-105GR	Green	525nm			
ELSB	ELSB-105RD	Red	625nm			
ELSB	ELSB-105IR	Infrared	850nm			

**ELSB-285**

Series	Part Number	Color	Wavelength / Color temperature	Max Power Consumption	Connectors	Weight
ELSB	ELSB-285SW	White	5500 K ± 500 K	80W	2 x M12-5 (M&F)	800g
ELSB	ELSB-285UV	Ultraviolet	405nm			
ELSB	ELSB-285BL	Blue	465nm			
ELSB	ELSB-285GR	Green	525nm			
ELSB	ELSB-285RD	Red	625nm			
ELSB	ELSB-285IR	Infrared	850nm			

**OPTICAL ACCESSORIES**

Polarizer	
Part Number	Applicable LED Unit
PL-ELSB-55	ELSB-55
PL-ELSB-105	ELSB-105
PL-ELSB-185	ELSB-185

For cables, please refer to the datasheet of the ECB cables series.

For fasteners and camera supports, please refer to the datasheet of the BK fasteners series.

CUSTOM - ON REQUEST

OPTION AVAILABLE ON REQUEST



#### EU DIRECTIVE



In accordance with EU machinery directive, EMC directive, and low voltage directive, machines and electronic devices not marked with the CE logo are subject to distribution restrictions within the EU. All EL Series LED illumination products excluding power supply conform to corresponding EN regulations. These products will maintain the EU mandate compatibility of our customers' machinery and electronic devices.

#### RoHS DIRECTIVE

All products from the EL Series comply with the RoHS Directive.





**FLEXIBLE POWER RING LIGHT**

**ELR SERIES**

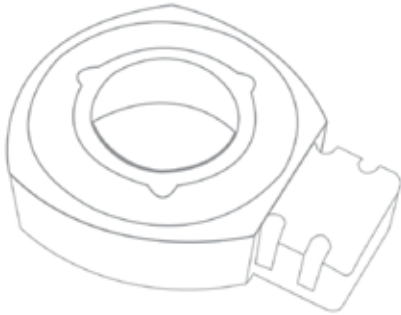

The ELR Series is a **highly flexible** power ring light. This series has an IP65 rating.

Users can easily adjust the lens position to meet any application requirements. The ELR Series is also shipped with three different diffuser plates, so that the uniformity can be adjusted to the needs of the user.

When compared to continuous mode, the **integrated controller** with **auto-strobe** functionality allows for a 700% increase in intensity while being strobed.

**MAIN FEATURES**

- Standard delivered as a package
- Very intense and uniform illuminated area
- Full range of color : from UV to IR, white
- Long lifetime and minimal maintenance
- Compatible with most objectives

Flexible: Adjustable illumination angles (4 angles) & different windows



Connector	M12 - 5 contacts	M8 - 4 contacts
Power supply	24VDC	Direct current (No driver = No protection)
Illumination mode	Strobe or continuous mode	
Wavelength	White, UV, Blue, Green, Red, IR	
Width x height	117 mm x 151 mm x 40 mm	
Fastener	M4 screw (4 on heat sink & 4 on outgrowth)	
Material	Device body: Aluminum alloy & ABS; Window: PMMA	
Working temperature	0° to 50° C	
IP code	IP65	

**APPLICATIONS**

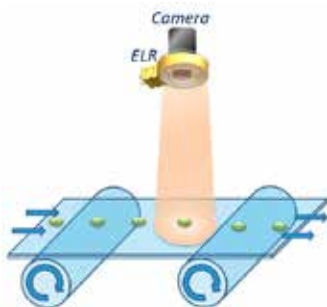

Quality control

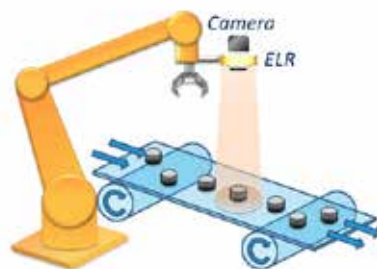

Pick & place





**ELECTRONICAL SPECIFICATIONS**

Contact arrangement

When using the ELR Series, please use a 24VDC power supply.  
Please note that the trigger pin needs to be connected when using the ELR Series.

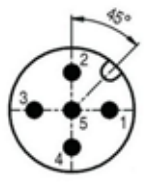
M12 connector - Smart control (Auto-strobe)			
Contact arrangement	Number	Color Contact	Designation
 M12 male connector	1	Brown	+24V
	2	White	n.a.
	3	Blue	GND
	4	Black	<b>PNP TRIGGER [trigger for rising edge] for auto-strobe</b> Light ON if $V_{PNP} > 3VDC$ max 24V - Analog Voltage
	5	Grey	n.a.

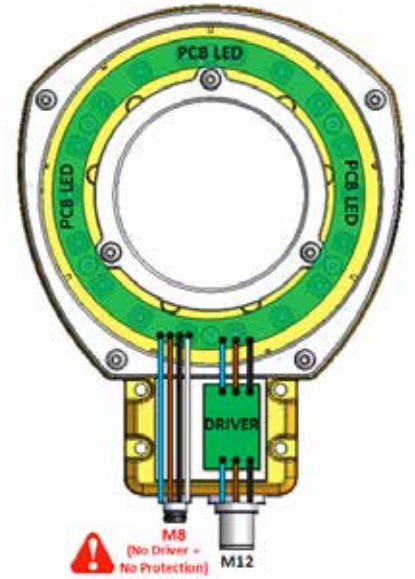

For direct-current-control, please use the M8 connector.

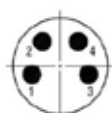
M8 connector - Direct control			
Contact arrangement	Number	Color Contact	Designation
 M8 male connector	1	Brown	+V <sub>common</sub>
	2	White	GND1
	3	Blue	GND2
	4	Black	GND3

Auto-strobe feature (M12 connector)

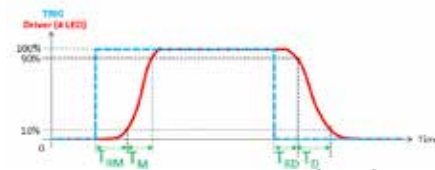
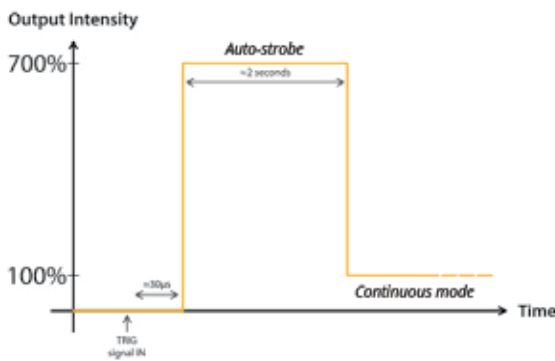

Designation	Time (µs)
Rise time ( $T_{R10}$ ) <sup>(1)</sup>	4-15
Response rise time ( $T_{R90}$ ) <sup>(2)</sup>	25
Fall time ( $T_{F10}$ ) <sup>(3)</sup>	10
Response fall time ( $T_{F90}$ ) <sup>(4)</sup>	5

- (1) From 10% to 90% of the peak value of driver signal
- (2) From 90% to 10% of the peak value of driver signal
- (3) From the beginning of the TRIG signal to 10% of the peak value of driver signal
- (4) From the ending of the TRIG signal to 90% of the peak value of driver signal
- (5)  $T_R$  increases when  $U_{LED}$  or/and the frequency increases

Direct current (M8 connector)

T pulse (µs)	F (Hz)				
	1	5	10	15	20
100 000	1.0 A				
50 000	1.2A				
10 000	1.5 A	1.0 A			
1000	2.0 A				
100	2.5 A				

Be aware that the maximum current for a given frequency and a given  $T_{pulse}$  cannot be exceeded.



**PRODUCT LINE UP - PACKAGES**

The ELR Series is standard delivered as a **package**: the product in the classic configuration (SD diffuser and the lens at P2 position) and the two other diffusers (DF and CW). This allows the users to select the correct diffuser for their application needs.



Part Number

The power consumption is given for white products, and may differ for other wavelengths. The power consumption will be specified on the products.

Series	Part Number	Color	Wavelength / Color temperature	Power Consumption (with M12 connector)		Connectors	Weight
				Strobe	Continuous		
ELR	ELR-100SW	White	5500 K ± 500 K	80W	15W	M12 & M8	400g
ELR	ELR-100UV	Ultraviolet	405nm	80W	15W	M12 & M8	400g
ELR	ELR-100BL	Blue	465nm	80W	15W	M12 & M8	400g
ELR	ELR-100GR	Green	525nm	80W	15W	M12 & M8	400g
ELR	ELR-100RD	Red	625nm	80W	15W	M12 & M8	400g
ELR	ELR-100IR	Infrared	850nm	80W	15W	M12 & M8	400g

**OPTICAL ACCESSORIES**

Polarizer	
Part Number	Applicable LED Unit
PL-ELR-100	ELR-100

For cables, please refer to the datasheet of the ECB cables series.  
For fasteners and camera supports, please refer to the datasheet of the BK fasteners series.

**CUSTOM - ON REQUEST**

OPTIONS AVAILABLE ON REQUEST

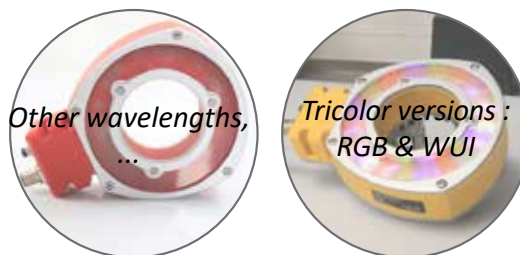

**EU DIRECTIVE**



In accordance with EU machinery directive, EMC directive, and low voltage directive, machines and electronic devices not marked with the CE logo are subject to distribution restrictions within the EU. All EL Series LED illumination products excluding power supply conform to corresponding EN regulations. These products will maintain the EU mandate compatibility of our customers' machinery and electronic devices.

**RoHS DIRECTIVE**

All products from the EL Series comply with the RoHS Directive.

## HOMOGENEOUS BACK LIGHT

### ELF SERIES

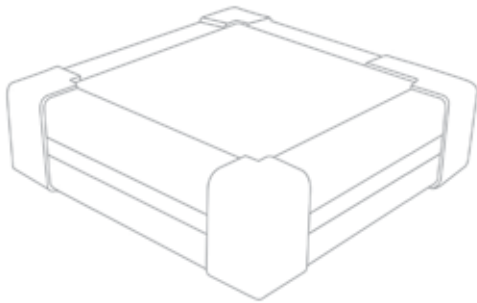

The ELF Series offers large area **back lights** with high uniformity and is designed with **high powered LEDs**.

It offers a **homogeneity** of more than 90% on the emitting surface, making it ideal for applications where uniform and diffused illumination is key. This gives the user the ability to accurately see the shape of work pieces in their application.

The ELF Series is designed with an **integrated dimming controller**, allowing for easy intensity adjustments.

### MAIN FEATURES

- Intense and homogeneous illumination
- Anti-reflection coating on the emitting surface
- Standard connections and fasteners
- Long life time and minimal maintenance



Connector	M12 - 4 contacts or M12P - 4 contacts (depending on the size)
Power supply	24VDC
Illumination mode	Continuous with a DIM process [0-24V] - Analog voltage or Strobe mode
Cable length	500mm
Available wavelength	White, Red, IR, Blue
Available sizes	From 200mmx200mm to 600mmx600mm
Thickness	43.2mm
Fastener	A groove all around the device
Material	Device body: Aluminum alloy & ABS; Window: Acrylic
Working temperature	0° to 50° C
IP code	IP50

### APPLICATIONS

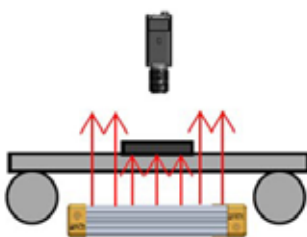

Inspection & Robotics

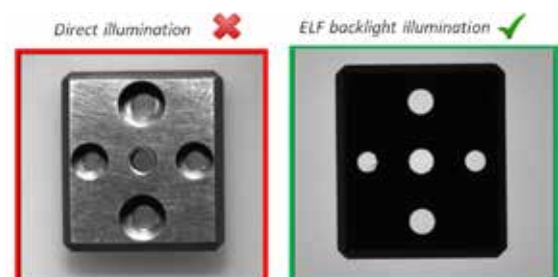

## OPTICAL CONSIDERATIONS

### Homogeneity

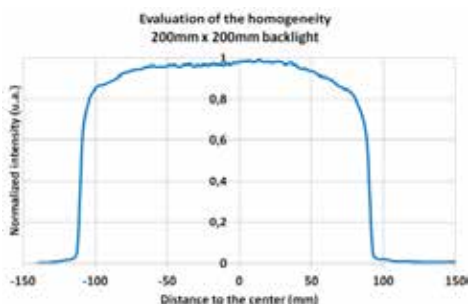

### Anti-reflection surface

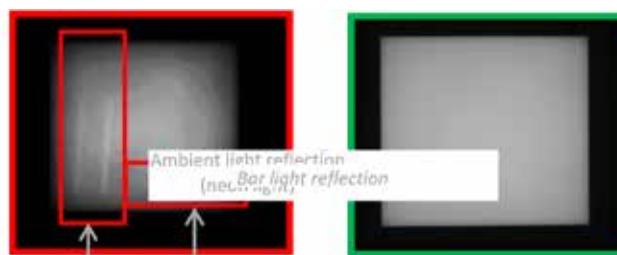

Thanks to the anti-reflection coating of the ELF Series, no more reflections visible.

## DIMENSIONS (MM)

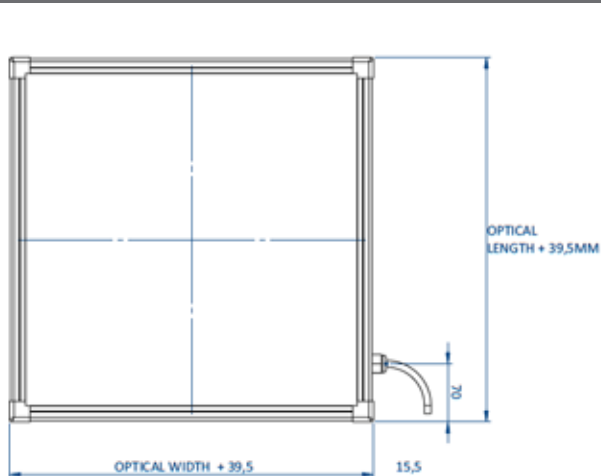



Length M12 Cable (Cable gland → Connector) : 500mm

## ELECTRONICAL SPECIFICATIONS

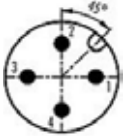

### Contact arrangement

When using the ELF Series, please use a 24VDC power supply.  
Please note that the AIC pin needs to be connected when using the ELF Series.

Contact arrangement	Number	Color Contact	Designation
  M12 male connector    M12 Power male connector  <i>TYPE OF CONNECTOR DEPENDS ON THE SIZE OF THE ELF</i>	1	Brown	+24V
	2	White	n.a.
	3	Blue	GND
	4	Black	<b>AIC: Analog Intensity Control for Dimming Control</b> Consumption depending on the size (between 0.3mA to 10mA) Suggested dimming range: min 5V - max 24V

### Dimming control feature

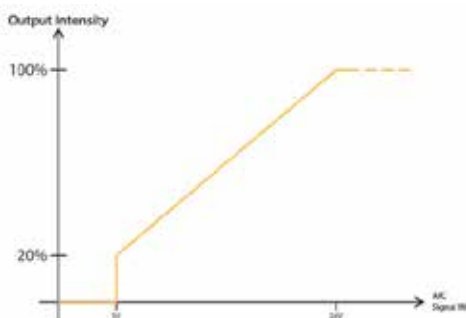

**PRODUCT LINE UP**

The power consumption is given for white products, and may differ for other wavelengths. The power consumption will be specified on the products.

Series	Part Number	Color	Wavelength / Color temperature	Max Power Consumption	Connector	Weight	Optical Width	Optical Length
ELF	ELF-200X200SW	White	5500 K ± 500 K	30W	M12	1 900g	200mm	200mm
ELF	ELF-200X200RD	Red	625nm					
ELF	ELF-200X200IR	Infrared	850nm					
ELF	ELF-200X200BL	Blue	465nm					
ELF	ELF-300X300SW	White	5500 K ± 500 K	65W	M12	3 500g	300mm	300mm
ELF	ELF-300X300RD	Red	625nm					
ELF	ELF-300X300IR	Infrared	850nm					
ELF	ELF-300X300BL	Blue	465nm					
ELF	ELF-400X400SW	White	5500 K ± 500 K	110W	M12P	5 000g	400mm	400mm
ELF	ELF-400X400RD	Red	625nm					
ELF	ELF-400X400IR	Infrared	850nm					
ELF	ELF-400X400BL	Blue	465nm					
ELF	ELF-500X500SW	White	5500 K ± 500 K	175W	M12P	7 900g	500mm	500mm
ELF	ELF-500X500RD	Red	625nm					
ELF	ELF-500X500IR	Infrared	850nm					
ELF	ELF-500X500BL	Blue	465nm					
ELF	ELF-600X600SW	White	5500 K ± 500 K	250W	M12P	12 800g	600mm	600mm
ELF	ELF-600X600RD	Red	625nm					
ELF	ELF-600X600IR	Infrared	850nm					
ELF	ELF-600X600BL	Blue	465nm					

For cables, please refer to the datasheet of the ECB cables series.

For fasteners and camera supports, please refer to the datasheet of the BK fasteners series of the BK fasteners series.

**CUSTOM - ON REQUEST**

Options available on request

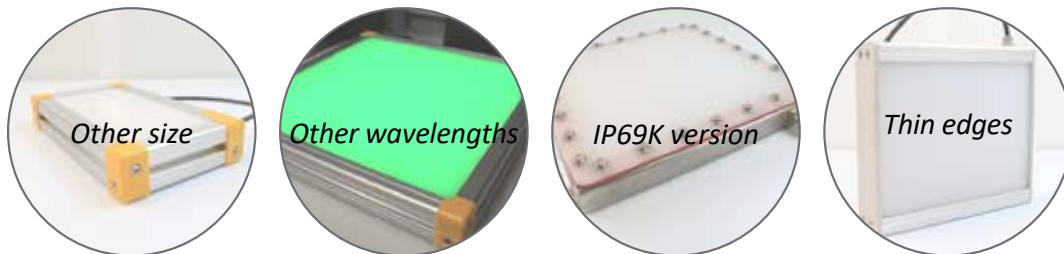

Example of custom

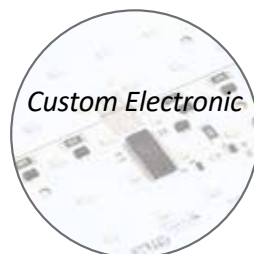

**EU DIRECTIVE**



In accordance with EU machinery directive, EMC directive, and low voltage directive, machines and electronic devices not marked with the CE logo are subject to distribution restrictions within the EU. All EL Series LED illumination products excluding power supply conform to corresponding EN regulations. These products will maintain the EU mandate compatibility of our customers' machinery and electronic devices.

**ROHS DIRECTIVE**

All products from the EL Series comply with the RoHS Directive.

## HOMOGENEOUS FLAT LIGHT WITH CAMERA HOLE

### ELF-C39 SERIES

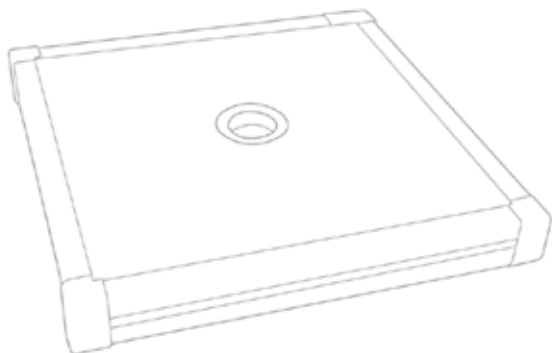

The ELF-C39 Series is a flat light with camera hole, offering **high uniformity** coupled with an **integrated dimming controller**.

This makes the ELF-C39 the ideal front light for highly reflective work pieces and applications with a large Field of View. The integrated dimming controller allows for easy intensity adjustments.

### MAIN FEATURES

- Intense illumination
- Diffuse light & high homogeneity
- Standard connections and fasteners
- Long life time and minimal maintenance



Connector	M12 - 4 contacts or M12P - 4 contacts (depending on the size)
Power supply	24VDC
Illumination mode	Continuous with a DIM process [0-24V] - Analog voltage or Strobe mode
Cable length	500mm
Available wavelength	White, Red, IR, Blue
Available sizes	From 200mmx200mm to 600mmx600mm
Thickness	43.2mm
Fastener	A groove all around the device
Material	Device body: Aluminum alloy & ABS; Window: Acrylic
Working temperature	0° to 50° C
IP code	IP50

### APPLICATIONS

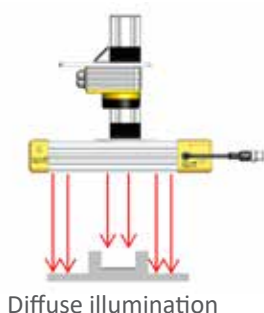

## DIMENSIONS (MM)

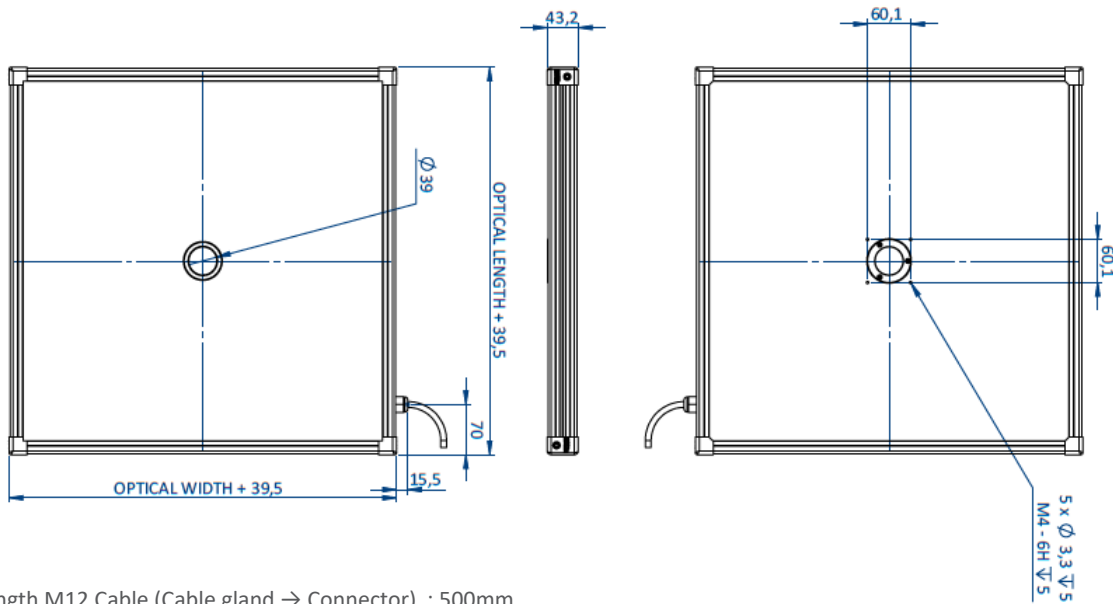

Length M12 Cable (Cable gland → Connector) : 500mm

## ELECTRONICAL SPECIFICATIONS



### Contact arrangement

When using the ELF-C39 Series, please use a 24VDC power supply.

Please note that the AIC contact needs to be connected when using the ELF-C39 Series.

Contact arrangement	Number	Color Contact	Designation
<p>M12 male connector    M12 Power male connector</p> <p><i>TYPE OF CONNECTOR DEPENDS ON THE SIZE OF THE ELF-C39</i></p>	1	Brown	+24V
	2	White	n.a.
	3	Blue	GND
	4	Black	<b>AIC: Analog Intensity Control for Dimming Control</b> Consumption depending on the size (between 0.3mA to 10mA) <b>Suggested dimming range: min 5V - max 24V</b>

### Dimming control feature

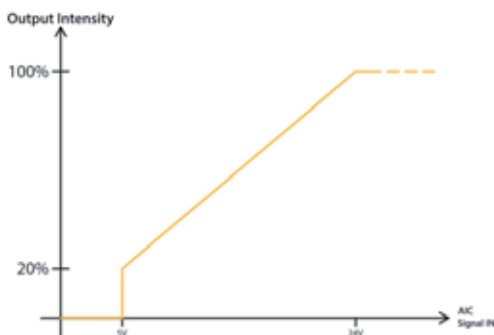

PRODUCT LINE UP

The power consumption is given for white products, and may differ for other wavelengths. The power consumption will be specified on the products.

Series	Part Number	Color	Wavelength / Color temperature	Max Power Consumption	Connector	Weight	Optical Width	Optical Length	Size of the camera hole
ELF-C	ELF-C39-200X200SW	White	5500 K ± 500 K	30W	M12	1 900g	200mm	200mm	39mm
ELF-C	ELF-C39-200X200RD	Red	625nm						
ELF-C	ELF-C39-200X200IR	Infrared	850nm						
ELF-C	ELF-C39-200X200BL	Blue	465nm						
ELF-C	ELF-C39-300X300SW	White	5500 K ± 500 K	65W	M12	3 500g	300mm	300mm	39mm
ELF-C	ELF-C39-300X300RD	Red	625nm						
ELF-C	ELF-C39-300X300IR	Infrared	850nm						
ELF-C	ELF-C39-300X300BL	Blue	465nm						
ELF-C	ELF-C39-400X400SW	White	5500 K ± 500 K	110W	M12P	5 000g	400mm	400mm	39mm
ELF-C	ELF-C39-400X400RD	Red	625nm						
ELF-C	ELF-C39-400X400IR	Infrared	850nm						
ELF-C	ELF-C39-400X400BL	Blue	465nm						
ELF-C	ELF-C39-500X500SW	White	5500 K ± 500 K	175W	M12P	7 900g	500mm	500mm	39mm
ELF-C	ELF-C39-500X500RD	Red	625nm						
ELF-C	ELF-C39-500X500IR	Infrared	850nm						
ELF-C	ELF-C39-500X500BL	Blue	465nm						
ELF-C	ELF-C39-600X600SW	White	5500 K ± 500 K	250W	M12P	12 800g	600mm	600mm	39mm
ELF-C	ELF-C39-600X600RD	Red	625nm						
ELF-C	ELF-C39-600X600IR	Infrared	850nm						
ELF-C	ELF-C39-600X600BL	Blue	465nm						

For cables, please refer to the datasheet of the ECB cables series.

For fasteners and camera supports, please refer to the datasheet of the BK fasteners series.

CUSTOM - ON REQUEST

Options available on request

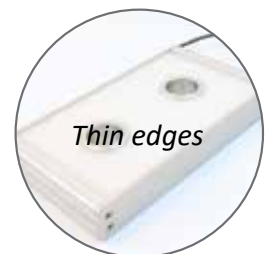
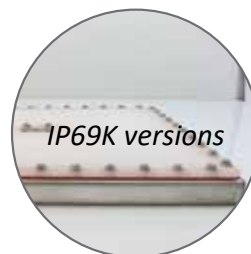
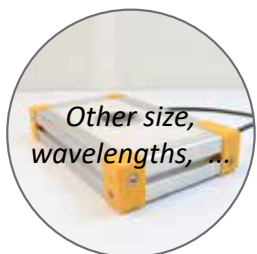

Example of custom



EU DIRECTIVE



In accordance with EU machinery directive, EMC directive, and low voltage directive, machines and electronic devices not marked with the CE logo are subject to distribution restrictions within the EU. All EL Series LED illumination products excluding power supply conform to corresponding EN regulations. These products will maintain the EU mandate compatibility of our customers' machinery and electronic devices.

RoHS DIRECTIVE

All products from the EL Series comply with the RoHS Directive.

## LINESCAN HOMOGENEOUS FLAT LIGHT

### ELFB SERIES



The ELFB Series is a line light with **high uniformity**, ideal for **linescan** applications where high uniformity is key.

Whether it is used as a front light or back light, the ELFB Series is flexible in its use. As such, it can be used for applications such as paper inspection, but also for inspection for foreign materials on clear film.

The ELFB Series is designed with an **integrated dimming controller**, allowing for easy intensity adjustments.

### MAIN FEATURES

- Very intense and uniform linescan LED light illumination
- Anti-reflection coating on the emitting surface
- Standard connections and fasteners
- Long life time and minimal maintenance



Connector	M12 - 4 contacts or M12P - 4 contacts (depending on the length)
Power supply	24VDC
Illumination mode	Continuous with a DIM process [0-24V] - Analog voltage or Strobe mode
Electronic mode	Dimming control [0-24V]
Available wavelength	White, Blue, Green, Red, IR
Available sizes	From 100mm to 1600mm
Width x height	51mm x 49mm
Fastener	One rail for M4 T-nut on the back and one rail for M6 T-nut on the side
Material	Device body: Aluminum alloy & ABS; Window: Acrylic
Working temperature	0° to 50° C
IP code	IP50

### APPLICATIONS

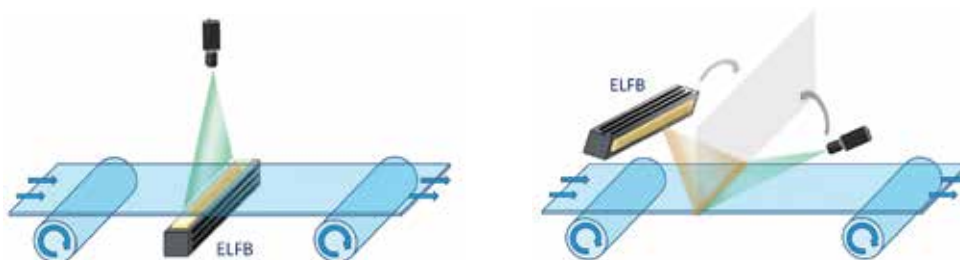

Linescan Inspection



OPTICAL CONSIDERATIONS

Homogeneity

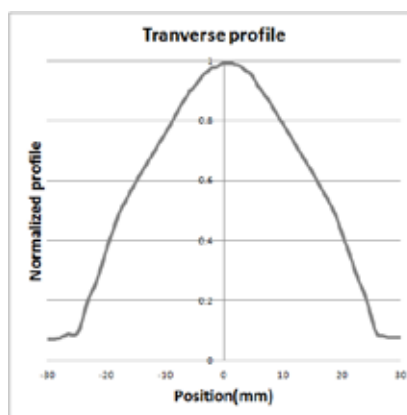
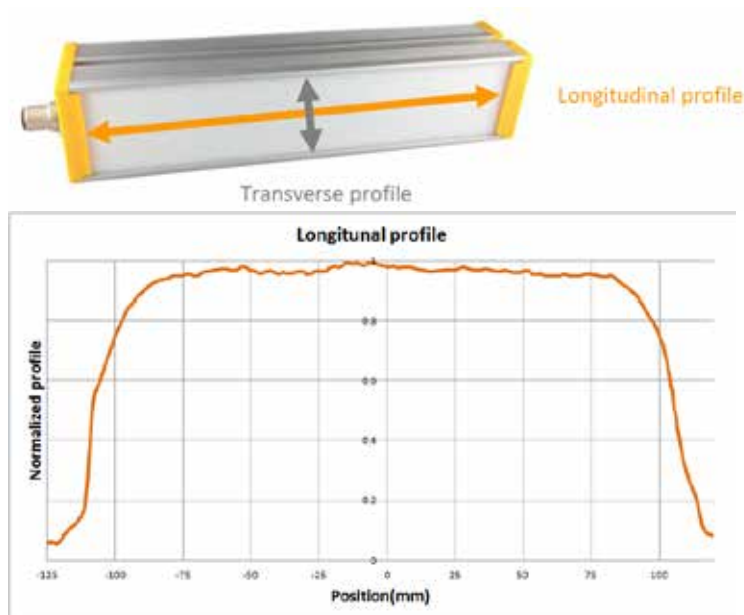

Longitudinal profil for the ELFB-200SW.

Optical options

The ELFB Series offer a cylindrical lens as an option, focusing the irradiation and increasing the intensity with a factor of 20.



With the polarizer for the ELFB Series, it is possible to eliminate glare from your workpiece, making it easier to acquire a suitable image for your application.



DIMENSIONS (MM)

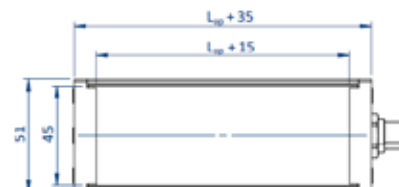
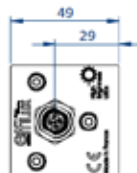
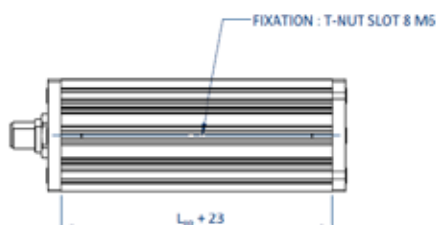
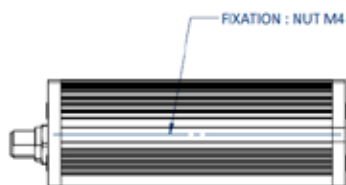



## ELECTRONICAL SPECIFICATIONS

### Contact arrangement

When using the ELFB Series, please use a 24VDC power supply.  
Please note that the AIC contact needs to be connected when using the ELFB Series.

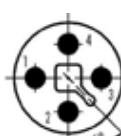
Contact arrangement	Number	Color Contact	Designation
  M12 male connector    M12 Power male connector <i>TYPE OF CONNECTOR DEPENDS ON THE SIZE OF THE ELFB</i>	1	Brown	+24V
	2	White	n.a.
	3	Blue	GND
	4	Black	<b>AIC: Analog Intensity Control for Dimming Control</b> Consumption : 0.5mA every 500mm length <b>Suggested dimming range: min 5V - max 24V</b>

### Dimming control feature

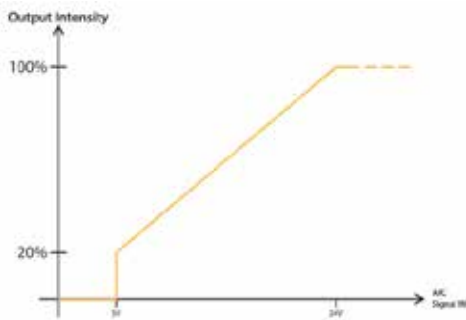

## PRODUCT LINE UP

The power consumption is given for white products, and may differ for other wavelengths. The power consumption will be specified on the products.

Series	Part Number	Color	Wavelength / Color temperature	Max Power Consumption	Connector	Weight	Optical Length (L <sub>op</sub> )
ELFB	ELFB-100SW	White	5500 K ± 500 K	5W	M12	400g	100mm
ELFB	ELFB-100BL	Blue	465nm				
ELFB	ELFB-100GR	Green	525nm				
ELFB	ELFB-100RD	Red	625nm				
ELFB	ELFB-100IR	Infrared	850nm				
ELFB	ELFB-200SW	White	5500 K ± 500 K	10W	M12	700g	200mm
ELFB	ELFB-200BL	Blue	465nm				
ELFB	ELFB-200GR	Green	525nm				
ELFB	ELFB-200RD	Red	625nm				
ELFB	ELFB-200IR	Infrared	850nm				
ELFB	ELFB-300SW	White	5500 K ± 500 K	15W	M12	1000g	300mm
ELFB	ELFB-300BL	Blue	465nm				
ELFB	ELFB-300GR	Green	525nm				
ELFB	ELFB-300RD	Red	625nm				
ELFB	ELFB-300IR	Infrared	850nm				
ELFB	ELFB-400SW	White	5500 K ± 500 K	20W	M12	1300g	400mm
ELFB	ELFB-400BL	Blue	465nm				
ELFB	ELFB-400GR	Green	525nm				
ELFB	ELFB-400RD	Red	625nm				
ELFB	ELFB-400IR	Infrared	850nm				
ELFB	ELFB-500SW	White	5500 K ± 500 K	25W	M12	1600g	500mm
ELFB	ELFB-500BL	Blue	465nm				
ELFB	ELFB-500GR	Green	525nm				
ELFB	ELFB-500RD	Red	625nm				
ELFB	ELFB-500IR	Infrared	850nm				

Series	Part Number	Color	Wavelength / Color temperature	Max Power Consumption	Connector	Weight	Optical Length (L <sub>op</sub> )
ELFB	ELFB-600SW	White	5500 K ± 500 K	30W	M12	1900g	600mm
ELFB	ELFB-600BL	Blue	465nm				
ELFB	ELFB-600GR	Green	525nm				
ELFB	ELFB-600RD	Red	625nm				
ELFB	ELFB-600IR	Infrared	850nm				
ELFB	ELFB-700SW	White	5500 K ± 500 K	35W	M12	2200g	700mm
ELFB	ELFB-700BL	Blue	465nm				
ELFB	ELFB-700GR	Green	525nm				
ELFB	ELFB-700RD	Red	625nm				
ELFB	ELFB-700IR	Infrared	850nm				
ELFB	ELFB-800SW	White	5500 K ± 500 K	40W	M12	2500g	800mm
ELFB	ELFB-800BL	Blue	465nm				
ELFB	ELFB-800GR	Green	525nm				
ELFB	ELFB-800RD	Red	625nm				
ELFB	ELFB-800IR	Infrared	850nm				
ELFB	ELFB-900SW	White	5500 K ± 500 K	45W	M12	2800g	900mm
ELFB	ELFB-900BL	Blue	465nm				
ELFB	ELFB-900GR	Green	525nm				
ELFB	ELFB-900RD	Red	625nm				
ELFB	ELFB-900IR	Infrared	850nm				
ELFB	ELFB-1000SW	White	5500 K ± 500 K	50W	M12	3100g	1000mm
ELFB	ELFB-1000BL	Blue	465nm				
ELFB	ELFB-1000GR	Green	525nm				
ELFB	ELFB-1000RD	Red	625nm				
ELFB	ELFB-1000IR	Infrared	850nm				
ELFB	ELFB-1100SW	White	5500 K ± 500 K	55W	M12	3400g	1100mm
ELFB	ELFB-1100BL	Blue	465nm				
ELFB	ELFB-1100GR	Green	525nm				
ELFB	ELFB-1100RD	Red	625nm				
ELFB	ELFB-1100IR	Infrared	850nm				
ELFB	ELFB-1200SW	White	5500 K ± 500 K	60W	M12	3700g	1200mm
ELFB	ELFB-1200BL	Blue	465nm				
ELFB	ELFB-1200GR	Green	525nm				
ELFB	ELFB-1200RD	Red	625nm				
ELFB	ELFB-1200IR	Infrared	850nm				
ELFB	ELFB-1300SW	White	5500 K ± 500 K	65W	M12	4000g	1300mm
ELFB	ELFB-1300BL	Blue	465nm				
ELFB	ELFB-1300GR	Green	525nm				
ELFB	ELFB-1300RD	Red	625nm				
ELFB	ELFB-1300IR	Infrared	850nm				
ELFB	ELFB-1400SW	White	5500 K ± 500 K	70W	M12	4300g	1400mm
ELFB	ELFB-1400BL	Blue	465nm				
ELFB	ELFB-1400GR	Green	525nm				
ELFB	ELFB-1400RD	Red	625nm				
ELFB	ELFB-1400IR	Infrared	850nm				
ELFB	ELFB-1500SW	White	5500 K ± 500 K	75W	M12	4600g	1500mm
ELFB	ELFB-1500BL	Blue	465nm				
ELFB	ELFB-1500GR	Green	525nm				
ELFB	ELFB-1500RD	Red	625nm				
ELFB	ELFB-1500IR	Infrared	850nm				
ELFB	ELFB-1600SW	White	5500 K ± 500 K	80W	M12P	4900g	1600mm
ELFB	ELFB-1600BL	Blue	465nm				
ELFB	ELFB-1600GR	Green	525nm				
ELFB	ELFB-1600RD	Red	625nm				
ELFB	ELFB-1600IR	Infrared	850nm				

**OPTICAL ACCESSORIES**

Cylindrical Lens	
Part Number	Applicable LED Unit
CL-ELFB-100	ELFB-100
CL-ELFB-200	ELFB-200
CL-ELFB-300	ELFB-300
CL-ELFB-400	ELFB-400
CL-ELFB-500	ELFB-500
CL-ELFB-600	ELFB-600
CL-ELFB-700	ELFB-700
CL-ELFB-800	ELFB-800
CL-ELFB-900	ELFB-900
CL-ELFB-1000	ELFB-1000
CL-ELFB-1100	ELFB-1100
CL-ELFB-1200	ELFB-1200
CL-ELFB-1300	ELFB-1300
CL-ELFB-1400	ELFB-1400
CL-ELFB-1500	ELFB-1500
CL-ELFB-1600	ELFB-1600

Polarizer	
Part Number	Applicable LED Unit
PL-ELB-100	ELB-100 / ELFB-100
PL-ELB-200	ELB-200 / ELB-L2-200 / ELFB-200
PL-ELB-300	ELB-300 / ELFB-300
PL-ELB-400	ELB-400 / ELB-L2-400 / ELFB-400
PL-ELB-500	ELB-500 / ELFB-500
PL-ELB-600	ELB-600 / ELB-L2-600 / ELFB-600
PL-ELB-700	ELB-700 / ELFB-700
PL-ELB-800	ELB-800 / ELB-L2-800 / ELFB-800
PL-ELB-900	ELB-900 / ELFB-900
PL-ELB-1000	ELB-1000 / ELB-L2-1000 / ELFB-1000
PL-ELB-1100	ELB-1100 / ELFB-1100
PL-ELB-1200	ELB-1200 / ELB-L2-1200 / ELFB-1200
PL-ELB-1300	ELB-1300 / ELFB-1300
PL-ELB-1400	ELB-1400 / ELB-L2-1400 / ELFB-1400
PL-ELB-1500	ELB-1500 / ELFB-1500
PL-ELB-1600	ELB-1600 / ELB-L2-1600 / ELFB-1600

For cables, please refer to the datasheet of the ECB cables series.

For fasteners and camera supports, please refer to the datasheet of the BK fasteners series.

**CUSTOM - ON REQUEST**

Options available on request



Example of custom

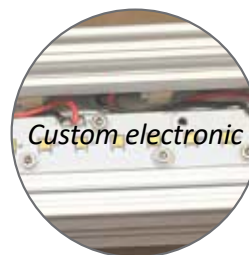

**EU DIRECTIVE**



In accordance with EU machinery directive, EMC directive, and low voltage directive, machines and electronic devices not marked with the CE logo are subject to distribution restrictions within the EU. All EL Series LED illumination products excluding power supply conform to corresponding EN regulations. These products will maintain the EU mandate compatibility of our customers' machinery and electronic devices.

**RoHS DIRECTIVE**

All products from the EL Series comply with the RoHS Directive.



**3D PROJECTOR**

**ELL SERIES**

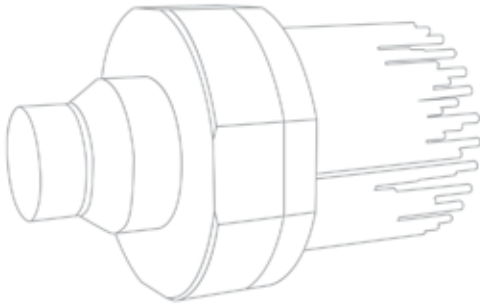

The ELL Series is a **structured light source**, which is ideal for 3D reconstruction applications or Stereo Vision applications.

This series offers great accuracy by using C-mount lens projection. The ELL Series offers three different masks: **Line, Grid, or Cloud of Dots**.

Since the ELL Series is a LED-based lighting solution, it is available in different colors. Furthermore, users do not have to worry about the speckle problem, eye safety, or lifetime issues. This makes the ELL Series the ideal substitute for lasers.

**MAIN FEATURES**

- Very intense and uniform illuminated area
- Long lifetime and minimal maintenance
- Compatible with most objectives (C-Mount)
- High depth of field for line version
- No speckle



	<b>PV (passive cooling) version</b>	<b>CP (compact) version</b>
Connector	M12 - 5 contacts	M8 - 8 contacts
Power supply	24VDC	Direct current (No driver = No protection)
Illumination mode	Strobe or continuous mode	Strobe mode only
Available wavelength	White, Blue, Green, Red, IR	White, Blue, Green, Red, IR
Projected pattern	Line, Grid, or Cloud of Dots	Line, Grid, or Cloud of Dots
Width x height	79.1mm x 150.6mm (without the objectives)	42mm x 71mm (without the objectives)
Fastener	8 x M5 holes on the sides of the device	8 x M5 holes on the sides of the device
Material	Device body: Aluminum alloy	Device body: Aluminum alloy
Working temperature	0° to 40° C	0° to 40° C
IP code	IP54	IP54

**APPLICATIONS**

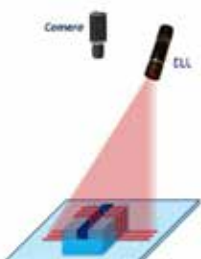

Stereovision and 3D profiling

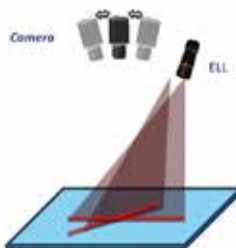

Alignment applications



ELL (up) VS LASER (down):  
no speckle = more accurate

OPTICAL CONSIDERATIONS

Masks

The ELL Series is available with different types of masks.

LINE (-LN)	CLOUD OF DOTS (-CD)	GRID (-GD)
1 line: 10µm line length : 13mm	Cloud of dots density 50% Surface 12.8x9.6 mm <sup>2</sup>	Grid 40x40 lines 50µm Surface 10x10 mm <sup>2</sup>

Pattern dimension

Depending on the working distance (WD) and the C-mount objective selected, different pattern sizes are obtained:

Objective	Line width Mask dimensions : 13mm x 10µm (-LN)			
	WD = 30 cm	WD = 50 cm	WD = 80 cm	WD = 100 cm
f = 12.5 mm	0.25 mm	0.40 mm	0.64 mm	0.80 mm
f = 16 mm	0.20 mm	0.32 mm	0.48 mm	0.60 mm
f = 35 mm	0.08 mm	0.14 mm	0.23 mm	0.28 mm
f = 50 mm	0.06 mm	0.10 mm	0.16 mm	0.20 mm
f = 75 mm	n.a.	n.a.	0.10 mm	0.13 mm

Objective	Pattern dimensions HxW Mask dimensions : 12.8mm x 9.6mm (-CD)			
	WD = 30 cm	WD = 50 cm	WD = 80 cm	WD = 100 cm
f = 12.5 mm	32cm x 23cm	51cm x 37cm	82cm x 59cm	102cm x 73cm
f = 16 mm	25cm x 19cm	41cm x 31cm	66cm x 49cm	82cm x 61cm
f = 35 mm	11cm x 8cm	18cm x 14cm	29cm x 22cm	36cm x 27cm
f = 50 mm	n.a.	12cm x 9cm	20cm x 15cm	25cm x 19cm
f = 75 mm	n.a.	n.a.	13cm x 10cm	16cm x 12cm

Alignment for line version

When using the line mask with the ELL Series, please align the mask with the LEDs to optimize the depth of field.

**DIMENSIONS (MM)**

ELL-CP : Compact version

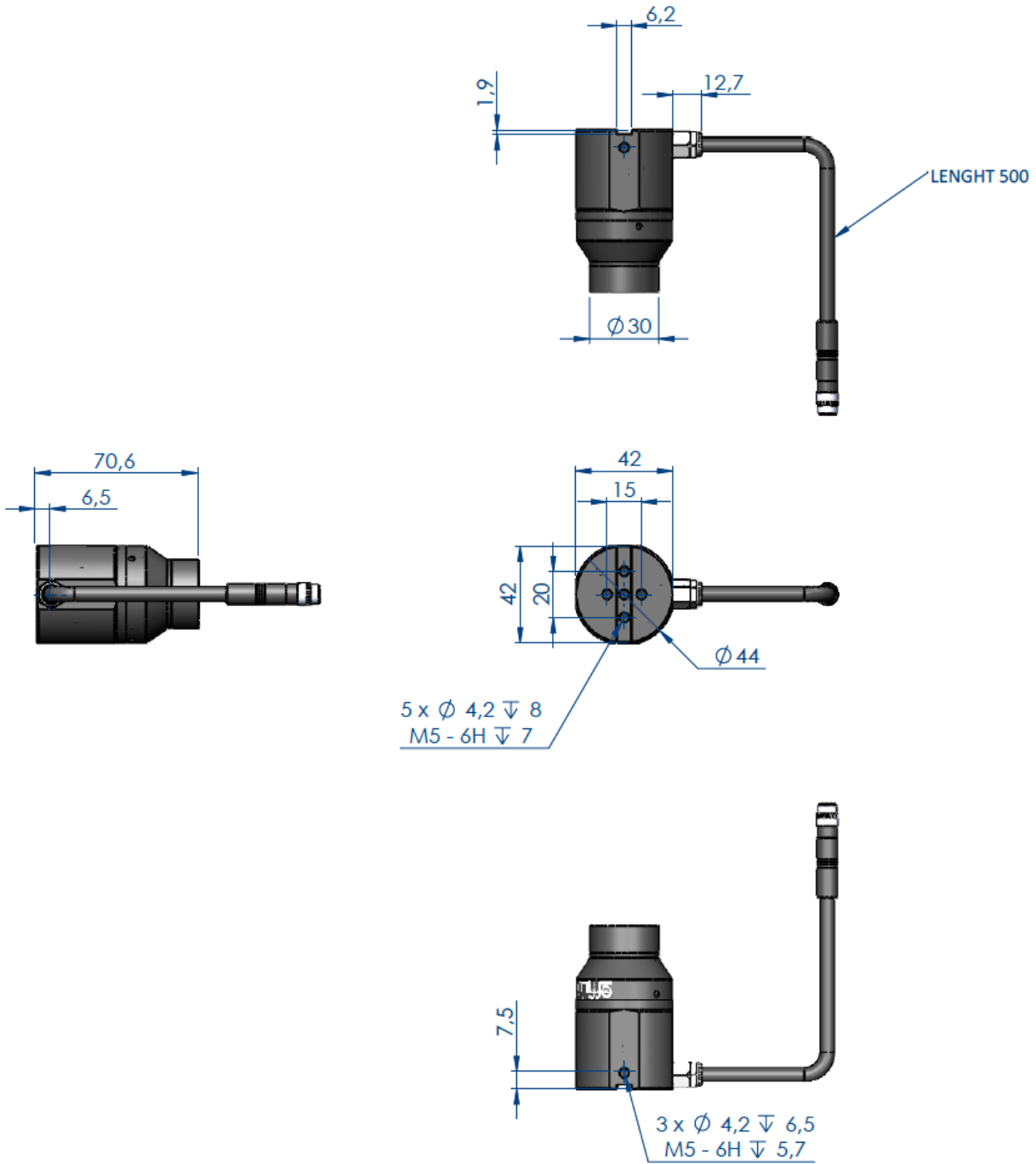



ELL-PV : Passive cooling version

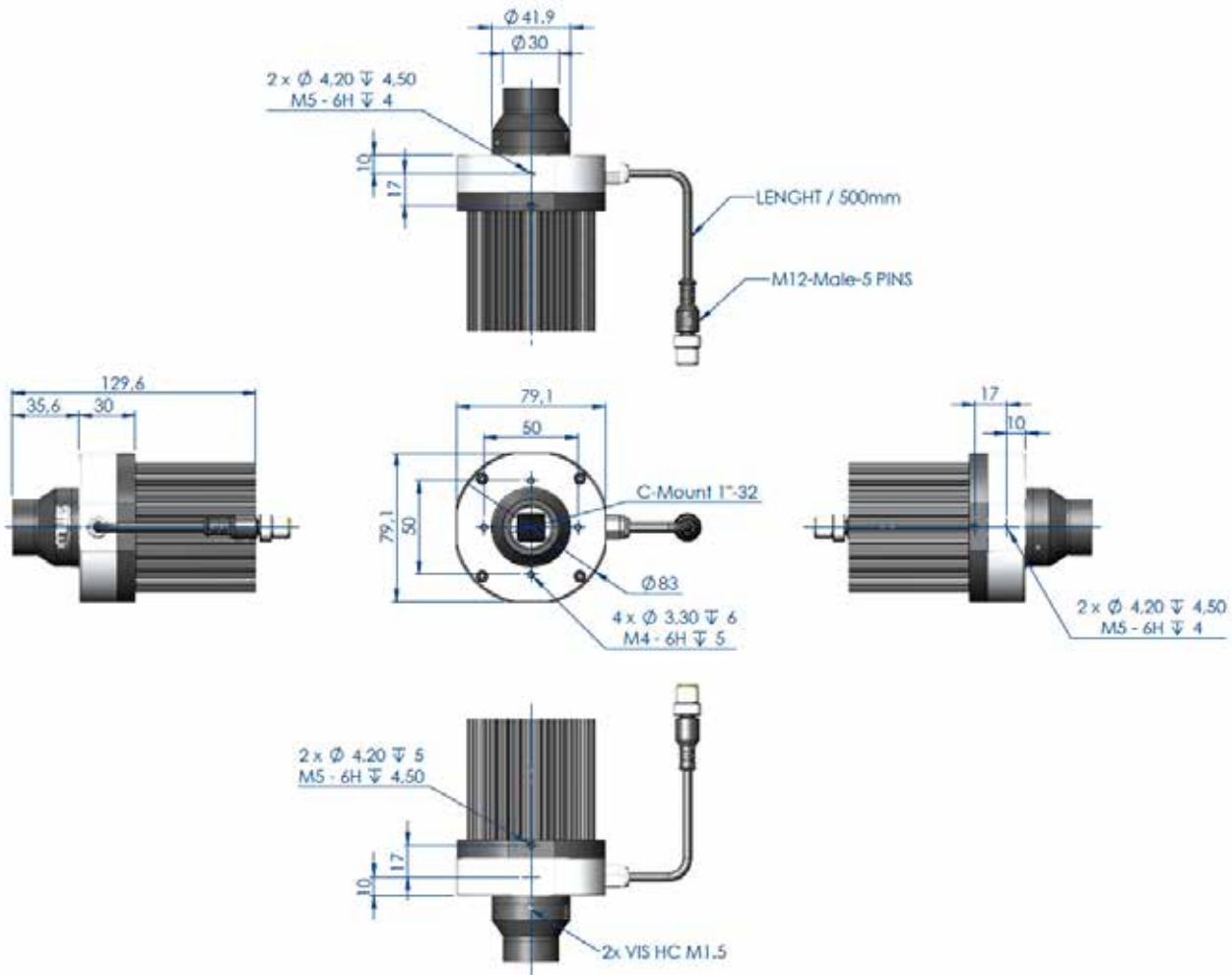

ELECTRONICAL CONSIDERATIONS - PV VERSION



Contact arrangement

When using the ELL Series, please use a 24VDC power supply.

Contact arrangement	Number	Color Contact	Designation
 <p>MALE</p> <p>M12 male connector</p>	1	Brown	+24V
	2	White	<b>NPN TRIGGER [trigger on falling edge] for auto-strobe</b> Light ON if $V_{NPN} < 1.5V$ DC <b>max 24V - Analog Voltage</b>
	3	Blue	GND
	4	Black	<b>PNP TRIGGER [trigger for rising edge] for auto-strobe</b> Light ON if $V_{PNP} > 3V$ DC <b>max 24V - Analog Voltage</b>
	5	Grey	<b>AIC: Analog Intensity Control for Dimming Control</b> <i>(If AIC is not connected, the light will light on at 100% as if VAIC = 24V. If you do not need to adjust light level, do not connect/use this PIN)</i> <b>Suggested dimming range: min 5V - max 24V</b>

Autostrobe feature and continuous mode

The integrated auto-strobe controller in the ELL Series is set to automatically strobe the LED. When the ELL Series is trigger shorter than 100µs, the LEDs are automatically overdriven at 2A. When the trigger is longer than 100µs, the ELL Series will automatically decrease the current to protect the LEDs.

If the duty cycle is larger than 0.3, the ELL Series will enter a protection mode to protect the LEDs and will stay off for 2 seconds. The ELL Series will check every 2 seconds if this duty cycle is maintained.

When using the ELL Series in continuous mode (set trigger continuously), the LED will be driven at 700mA.

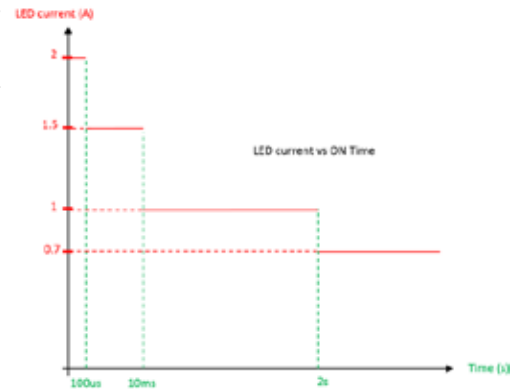

Dimming control

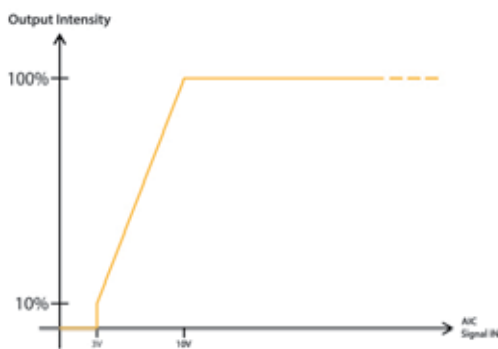

By adjusting the analog tension, light intensity can be controlled from 10% to 100%.

If the Input AIC is not connected, the ELL will act as if AIC was set at 24V.

**ELECTRONICAL CONSIDERATIONS - CP VERSION**



Contact arrangement

The ELL-CP is supplied with direct current through the M8-8 contacts (male).

Contact arrangement	Number	Color Contact	Designation
<p>M8 8 contacts male connector</p>	1	White	-V <sub>LED</sub>
	2	Brown	+V <sub>LED</sub>
	3	Green	n.a.
	4	Yellow	n.a.
	5	Grey	n.a.
	6	Pink	n.a.
	7	Blue	-TH (Thermistor)
	8	Red	+TH (Thermistor)

Direct current mode

You can see below 5 possible configurations depending on the current that you provide to the ELL-CP. *Contact CCS for more information.*

Configuration	Current	Max pulse duration (µs) / τ <sub>pulse</sub>	D
1	1.2A	50 000	0.5
2	1.5A	10 000	0.1
3	2A	1 000	0.01
4	2.5A	100	0.001
5	3.5A	40	0.0004

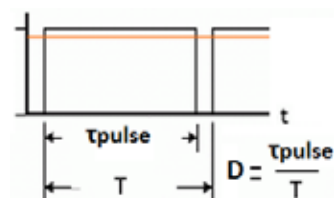

## PRODUCT LINE UP

The power consumption is given for white products, and may differ for other wavelengths. The power consumption will be specified on the products.

### ELL-CP : Compact version

Series	Part Number	Color	Wavelength / Color temperature	Connector	Weight	Pattern
ELL	ELL-CP-30SW-LN	White	5500 K ± 500 K	M8	200g	Line
ELL	ELL-CP-30BL-LN	Blue	465nm			
ELL	ELL-CP-30GR-LN	Green	525nm			
ELL	ELL-CP-30RD-LN	Red	625nm			
ELL	ELL-CP-30IR-LN	Infrared	850nm			
ELL	ELL-CP-30SW-CD	White	5500 K ± 500 K	M8	200g	Cloud of dots
ELL	ELL-CP-30BL-CD	Blue	465nm			
ELL	ELL-CP-30GR-CD	Green	525nm			
ELL	ELL-CP-30RD-CD	Red	625nm			
ELL	ELL-CP-30IR-CD	Infrared	850nm			
ELL	ELL-CP-30SW-GD	White	5500 K ± 500 K	M8	200g	Grid
ELL	ELL-CP-30BL-GD	Blue	465nm			
ELL	ELL-CP-30GR-GD	Green	525nm			
ELL	ELL-CP-30RD-GD	Red	625nm			
ELL	ELL-CP-30IR-GD	Infrared	850nm			

### ELL-PV : Passive cooling version

Series	Part Number	Color	Wavelength / Color temperature	Power Consumption		Connector	Weight	Pattern
				Strobe	Continuous			
ELL	ELL-PV-30SW-LN	White	5500 K ± 500 K	45W	15W	M12	400g	Line
ELL	ELL-PV-30BL-LN	Blue	465nm					
ELL	ELL-PV-30GR-LN	Green	525nm					
ELL	ELL-PV-30RD-LN	Red	625nm					
ELL	ELL-PV-30IR-LN	Infrared	850nm					
ELL	ELL-PV-30SW-CD	White	5500 K ± 500 K	45W	15W	M12	400g	Cloud of dots
ELL	ELL-PV-30BL-CD	Blue	465nm					
ELL	ELL-PV-30GR-CD	Green	525nm					
ELL	ELL-PV-30RD-CD	Red	625nm					
ELL	ELL-PV-30IR-CD	Infrared	850nm					
ELL	ELL-PV-30SW-GD	White	5500 K ± 500 K	45W	15W	M12	400g	Grid
ELL	ELL-PV-30BL-GD	Blue	465nm					
ELL	ELL-PV-30GR-GD	Green	525nm					
ELL	ELL-PV-30RD-GD	Red	625nm					
ELL	ELL-PV-30IR-GD	Infrared	850nm					

For cables, please refer to the datasheet of the ECB cables series.

For fasteners and camera supports, please refer to the datasheet of the BK fasteners series.

## CUSTOM - ON REQUEST

### Example of custom

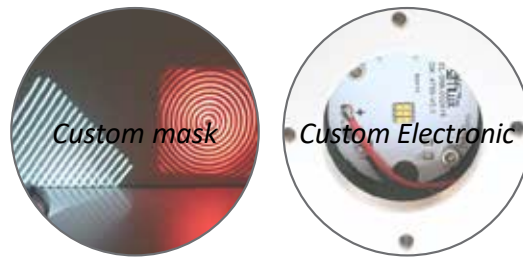

## EU DIRECTIVE



In accordance with EU machinery directive, EMC directive, and low voltage directive, machines and electronic devices not marked with the CE logo are subject to distribution restrictions within the EU. All EL Series LED illumination products excluding power supply conform to corresponding EN regulations. These products will maintain the EU mandate compatibility of our customers' machinery and electronic devices.

## ROHS DIRECTIVE

All products from the EL Series comply with the RoHS Directive.

## CABLES

### ECB SERIES



Series	Characteristics	Part Number	Length
ECB	M12 - Female - 5 pins	ECB-2-FL	2m
		ECB-5-FL	5m
		ECB-10-FL	10m
ECB	M12 - Female / Male - 5 pins	ECB-2	2m
		ECB-5	5m
		ECB-10	10m
ECB-P	M12 Power - Female - 5 pins	ECB-P-2-FL	2m
		ECB-P-5-FL	5m
		ECB-P-10-FL	10m
ECB-P	M12 Power - Female / Male - 5 pins	ECB-P-2	2m
		ECB-P-5	5m
		ECB-P-10	10m
ECB-M8	M8 - Female - 4 pins	ECB-M8-2-FL	2m
		ECB-M8-5-FL	5m
		ECB-M8-10-FL	10m
ECB-8	M8 - Female - 8 pins	ECB-8-2-FL	2m
		ECB-8-5-FL	5m
		ECB-8-10-FL	10m

## CAMERA FIXING & LIGHTINGS FASTENERS

### BK & AD SERIES

#### CAMERA FIXINGS

Camera mounting brackets for combining a light with a camera.

Series	Part Number	Compatibility	Pictures
BK	BK-EL-CM-VE	ELR ELF-C	
BK	BK-EL-CM-HO	ELR ELF-C	

#### LIGHTINGS FASTENERS

Series	Fastener	Picture	Part Number	Characteristics	Compatibility
BK	T-Nut		BK-EL-BOLT-M6	This kit contains 1 T-NUT M6 nut, 1 M6X14 screw, 1 M6 washer, 1 M4X12 screw, 1 M4 washer and 1 M4 nut.	ELF, ELF-C, ELB
			BK-EL-BOLT-M4	This kit contains 1 T-NUT M4 nut, 1 M4x8 screw and 1 M4x12 screw and 1 M4 washer.	
BK	Bracket		BK-EL	This fastener is attached in the product profile with a T-Nut and the desired mechanical support via a second T-Nut. Delivered with 2 M6x14 screws, 2 M6 T-NUT nuts and 2 M6 washers	ELF, ELF-C, ELB
			BK-EL-GRV		
			BK-EL-GRV-2		
BK	"Elcom" Ball		BK-EL-BALL-DL	Delivered with 2 M4x10 screws, 1 M6x14 screw, 2 M5x10 screws and 1 T-NUT M6 nut.	ELL
			BK-EL-BALL-NDL	Supplied with 2 T-NUT M6 nuts, 1 M4 T-NUT nut, 1 M6x14 screw, 1 M6x10 screw, 1 M4x10 screw, 1 M5x8 screw, and 1 M5x10 screw.	ELF, ELF-C, ELB, ELSB, ELL-CP
AD	ELSB Adapter		AD-ELSB	Adapter for fastening your ELSB. Delivered with 2 M3x8 screws. To securely lock the product, please remove the inner washers.	ELSB

## INFORMATION

### EU DIRECTIVE



In accordance with EU machinery directive, EMC directive, and low voltage directive, machines and electronic devices not marked with the CE logo are subject to distribution restrictions within the EU. All EL Series LED illumination products excluding power supply conform to corresponding EN regulations. These products will maintain the EU mandate compatibility of our customers' machinery and electronic devices.

### RoHS DIRECTIVE

All products listed in this catalog comply with the RoHS Directive.

### WARRANTY INFORMATION

EXCEPT FOR THE EXPRESS WARRANTIES STATED IN THIS DOCUMENT, CCS MAKES NO ADDITIONAL WARRANTIES, EXPRESS, IMPLIED, OR STATUTORY, AS TO ANY MATTER WHATSOEVER. IN PARTICULAR, ANY AND ALL WARRANTIES OF MERCHANTABILITY OR FITNESS FOR PARTICULAR PURPOSE ARE EXPRESSLY EXCLUDED. EXCEPT AS EXPRESSLY SET FORTH HEREIN, CCS MAKES NO WARRANTIES WITH RESPECT TO THE PRODUCTS.

WARRANTY PERIOD: EL SERIES PRODUCTS HAVE A WARRANTY OF 2 YEARS (ONE YEAR FOR RADIANT QUANTITY) FROM THE DATE THE PRODUCT IS SHIPPED FROM THE MANUFACTURER. CCS WILL REPAIR OR REPLACE THE PRODUCT FREE OF CHARGE IF IT SHOULD FAIL TO FUNCTION OR IF THE RADIANT QUANTITY OF THE PRODUCT SHOULD DROP TO 50% OR LESS OF ITS INITIAL RADIANT QUANTITY WITHIN THE SPECIFIED WARRANTY PERIOD. IF EITHER OF THESE CONDITIONS OCCURS, PLEASE TAKE THE PRODUCT TO YOUR CCS SALES REPRESENTATIVE.

**EXCEPTIONS:**

- UV PRODUCTS (WAVELENGTH UNDER 420NM) HAVE A WARRANTY OF 1 YEAR.
- POLARIZERS HAVE NO WARRANTY.

### WARRANTY TERMS

1. CCS WILL REPAIR OR REPLACE THE PRODUCT FREE OF CHARGE IF IT SHOULD FAIL TO FUNCTION UNDER USE ON OUR SPECIFIED CONDITION IN ACCORDANCE WITH THE INSTRUCTION GUIDE AND OTHER WRITTEN CAUTIONS DURING THE INDICATED WARRANTY PERIOD OF TWO YEARS.
2. CCS WILL REPAIR OR REPLACE THE PRODUCT FREE OF CHARGE IF ITS RADIANT QUANTITY SHOULD DROP TO 50% OR LESS OF ITS INITIAL RADIANT QUANTITY UNDER USE ON OUR SPECIFIED CONDITION IN ACCORDANCE WITH THE INSTRUCTION GUIDE AND OTHER WRITTEN CAUTIONS DURING THE INDICATED WARRANTY PERIOD OF ONE YEAR.
3. CCS WILL CHARGE A REPAIR FEE UNDER THE FOLLOWING CONDITIONS:
  - 1) IF THE PRODUCT HAS BEEN SUBJECTED TO MISUSE, UNAUTHORIZED REPAIRS, OR MODIFICATION FROM ITS ORIGINAL DESIGN.
  - 2) IF THE PRODUCT HAS BEEN DAMAGED FROM IMPACTS DUE TO INAPPROPRIATE HANDLING.
  - 3) IF DAMAGE TO THE PRODUCT RESULTS FROM EXTERNAL CAUSES INCLUDING ACCIDENTS, FIRE, POLLUTION, RIOTS, COMMUNICATION FAILURES, EARTHQUAKES, THUNDERSTORMS, WIND AND FLOOD DAMAGE, OR ANY OTHER ACT OF PROVIDENCE, OR FROM ANY EXTRAORDINARY CONDITIONS SUCH AS ELECTRICAL SURGES, WATER LEAKAGE, CONDENSATION, OR THE USE OF CHEMICALS.
  - 4) IF THE DAMAGE RESULTS FROM CONNECTION TO ANY POWER SUPPLY OR TO ANY EQUIPMENT WHICH CCS DOES NOT MANUFACTURE OR DOES NOT SPECIFY FOR USE.
4. CCS ASSUMES NO LIABILITY FOR ANY PURCHASER'S SECONDARY DAMAGE (DAMAGE OF EQUIPMENT, LOSS OF OPPORTUNITIES, LOSS OF PROFITS, ETC.) OR ANY OTHER DAMAGE RESULTING FROM A FAILURE OF OUR PRODUCT.

THIS WARRANTY INFORMATION PROVIDES THE SCOPE OF CCS'S PRODUCT WARRANTY WITHIN THE SPECIFIED PERIOD, AND DOES NOT INDICATE OR IMPLY ANY FURTHER GUARANTEE BEYOND THE WARRANTY TERMS. CONTACT CCS FOR INQUIRIES OR INFORMATION ON REPAIRS TO THE PRODUCT AFTER THE EXPIRATION OF THE WARRANTY.

NOTE: THE RADIANT QUANTITY REFERS TO THE WATTAGE OF PHYSICAL ENERGY RADIATED FROM AN LED. IT REFERS TO THE RADIATION LUMINOSITY OF THE LED MEASURED UNDER CONDITIONS SPECIFIED BY CCS OR THE RADIATION ILLUMINATION OF THE LED UNDER SPECIFIED IRRADIATION CONDITIONS. CCS SPECIFIES THE RADIANT QUANTITY FOR EACH LED LIGHT BECAUSE THE MEASUREMENT AND IRRADIATION CONDITIONS VARY FROM THE FORM, THE APPLICATION AND THE IRRADIATION WAVELENGTH.

Supported by CCS  
Your Lighting Partner  
[www.el-series.com](http://www.el-series.com)

**CCS America, Inc.**

6 Lincoln Knoll Lane, Suite 102  
Burlington, MA 01803 USA  
T: (1) 781 272 6900 F: (1) 781 272 6902  
[info@ccsamerica.com](mailto:info@ccsamerica.com)

**CCS Europe N.V.**

Bergensesteenweg 421B  
1600 Sint-Pieters-Leeuw, Belgium  
T: (32) 2 333 0080 F: (32) 2 333 00 81  
[info@ccseu.com](mailto:info@ccseu.com)

**CCS Inc.**

38 Konoecho, Demizu-Agaru, Muromachi-dori,  
Kamigyō-ku, Kyoto 602-8019, Japan  
T: (81) 75 415 8280 F: (81) 75 415 8281